

# SANGAMO

Fit & forget...

## Choice PR1n - 1 Channel Programmer

Installation Instructions



### Technical Data

Power Supply:	230V AC, 50Hz
Operating Temperature:	0°C to 40°C
Switch Rating:	230V AC, 2(1)A
Contact Type:	1B, Micro-Disconnection (Voltage Free)
Battery Type:	Lithium Cell CR2032
Enclosure Protection	IP30
Plastics	Thermoplastic, flame retardant
Insulation Class	Double
Wiring:	For fixed wiring only
Backplate	Industry standard
Dimensions:	140mm x 87mm x 37mm
Clock	12 hour am/pm, 1 minute resolution
Summer/Winter time change	Automatic
Clock Accuracy	+/- 1.5 sec/day
Program Cycle	24hr, 5/2day or 7day selectable.
Program On/off per day	2on/off, 3on/off selectable
Program Resolution	10mins
Program Selection	Auto, On all day, On constant, Off
Program Override	+1,2 or 3 Hr Boost & Advance to next program
Complies with	EN60730-1, EN60730-2.7, EMC Directive 2004/108/EC, LVD Directive 2006/95/EC

### Pre-Installation Set Up

Before installing, set the bank of 4 DIP Switches on the back to configure the unit according to the chart below:

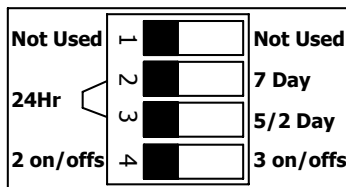

DIP Switches Shown in Factory Default Positions. (black = raised actuator of switch)

**24 Hr** Runs same programme every day.

**5/2 Day** Allows different on/off times at weekend.

**7 Day** Allows different on/off times every day.

### Installation Safety Notes

This unit must be installed by a suitably qualified person in accordance with the latest IEE Wiring Regulations.

Isolate mains supply before commencing installation. Please read all installation instructions before proceeding.

Ensure that the fixed wiring connections to the mains supply is via a fuse rated at not more than 3 amps and a class 'A' switch having a contact separation of a minimum of 3mm in all poles. The recommended cable sizes are 1.0mm<sup>2</sup> or 1.5mm<sup>2</sup>

If the unit is fitted to a metal surface, **IT IS ESSENTIAL** that the metal be earthed. **DO NOT** use a surface mounting box.

No earth connection is required as the product is double insulated but ensure continuity of earth throughout the system.

### Fitting Back Plate – Direct Wall Mounting

1. Position the back-plate (terminals along top edge) with 100mm (min) clearance to its right, 25mm (min) above, 10mm (min) below and left. Ensure that the supporting surface will fully cover the back of the programmer.
2. The ideal location would be 1.4M above floor level, easily accessible, reasonably lit and free from condensation or temperature extremes.
3. Offer the back plate to the wall in the position where the programmer is to be mounted remembering that the back plate fits to the left hand side of the programmer. Mark the fixing positions through the slots in the backplate, drill and plug wall, then secure back plate in position using screws.
4. All necessary electrical connections should now be made. Ensure that the wiring to the back-plate terminals leads directly away from the terminals and is completely enclosed within the back-plate aperture. Wire ends must be stripped and screwed to the terminals so that minimal bare wire is showing.

### Fitting Back Plate – Wiring Box Mounting

1. Fix the back-plate to a flush mounting single conduit box type UA1 (BS4662) using M3.5 x 14 screws. Take care to ensure the opening is adequate and will allow mounting of the unit onto the back-plate. The use of glue, mastic, or other sealants **MUST NOT**

2. be used to secure the unit to the wall.
2. All necessary electrical connections should now be made. Ensure that the wiring to the back-plate terminals leads directly away from the terminals and is completely enclosed within the back-plate aperture. Wire ends must be stripped and screwed to the terminals so that minimal bare wire is showing.

### New Installations

Example circuit diagrams for typical installations are shown over. These diagrams are schematic and should be used as a guide only. Please ensure that all installations comply with the current IEE regulations.

For reasons of space and clarity not every system has been included and the diagrams have been simplified, for instance some Earth connections have been omitted.

Other control components shown in the diagrams i.e. Valves, Room Stats etc. are general representations only. However the wiring detail can be applied to the corresponding models of most manufacturers.

Continued Over...

## New Installations

Cylinder and Room Thermostat Key:

C=Common Call = Call for heat or break on rise SAT = Satisfied on rise N= Neutral

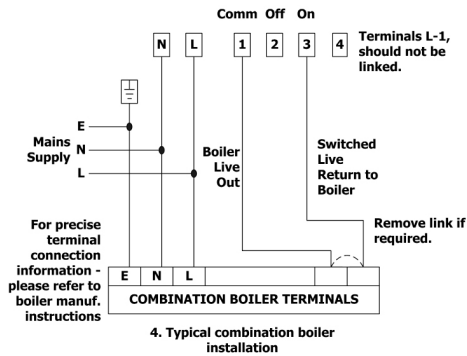
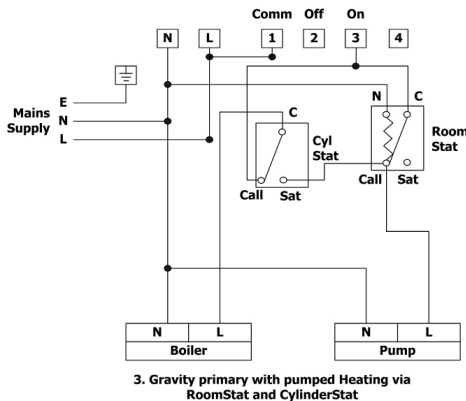
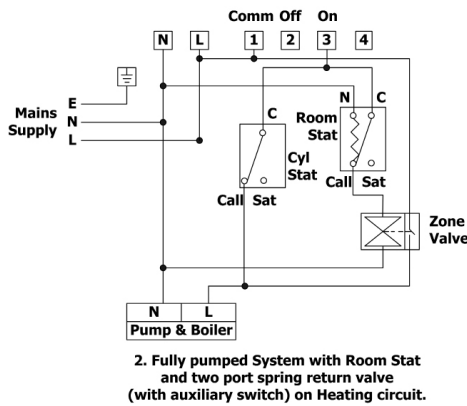
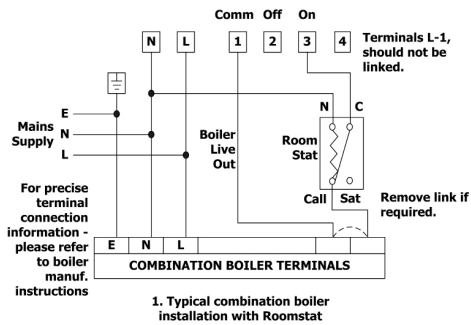

## Existing Installations

1. Remove old programmer from its back plate mounting loosening any securing screws as dictated by its design.
2. Check compatibility of existing back plate & wiring arrangement with that of the new programmer. See online Programmer Compatibility Guide for direction.
3. Make all necessary changes to back plate & wiring arrangement to suit new programmer

## Electrical Connections

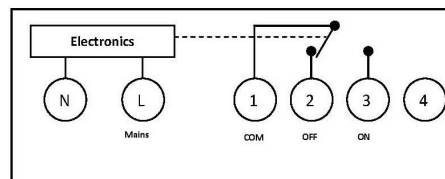

Note: The switch is volt free. Com should be linked to L for mains switching.

## Fitting The Programmer

Loosen the two retaining screws on the bottom of the back plate.

Now fit the programmer to the back plate, ensuring the lugs of the back plate engage with the slots on the programmer.

Swing the bottom of the programmer into position ensuring the connection pins on the back of the unit locate into the terminal slots in the back plate.

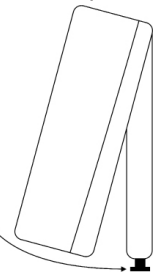

Tighten the two screws to fix the unit securely.

## Commissioning

Switch on mains supply. Referring to the user guide:

1. Use the buttons to ensure correct product functionality.
2. Set timing and programme details in accordance with customer requirements.
3. Normally unit will be left with channel in 'Auto' mode.
4. Leave these installation instructions with customer for reference.

In the interests of continuous product improvement we reserve the right to alter designs, specifications and materials without prior notice and cannot accept liability for errors.

If you have a problem or require any further information please contact our technical team on:

**01475 745131**

**Sangamo Limited**  
Industrial Estate, Port Glasgow,  
Renfrewshire, PA14 5XG

Tel 01475 745131

Fax: 01475 744567

Email: [enquiries@sangamo.co.uk](mailto:enquiries@sangamo.co.uk)

Web: [www.sangamo.co.uk](http://www.sangamo.co.uk)

### SERVICE AND WARRANTY

Your product is not user serviceable. **PLEASE DO NOT TRY TO DISMANTLE THE UNIT.**

This product is guaranteed by your supplier for 5 years from the date of manufacture. If it should become defective please contact your installer or supplier for a replacement unit or visit [www.sangamo.co.uk/returns](http://www.sangamo.co.uk/returns)

This product must meet Waste Electronic and Electrical Equipment Regulations (WEEE) for suitable environmental recycling, recovery and/or disposal. End of life products should be handled in line with local regulations. Alternatively return end of life product to Sangamo for correct disposal.

### CUSTOMER CARE POLICY

As part of Sangamo's continuous improvement program, the company operates a Customer Care policy. This means we welcome your comments and complaints, as it can help us to improve our services to you, our customer.

Due to our policy of continuous product improvement and development, the specifications in this guide may be subject to change without prior notice.



# SANGAMO

Fit & forget...

## Choice PR1n - 1 Channel Programmer

User Instructions

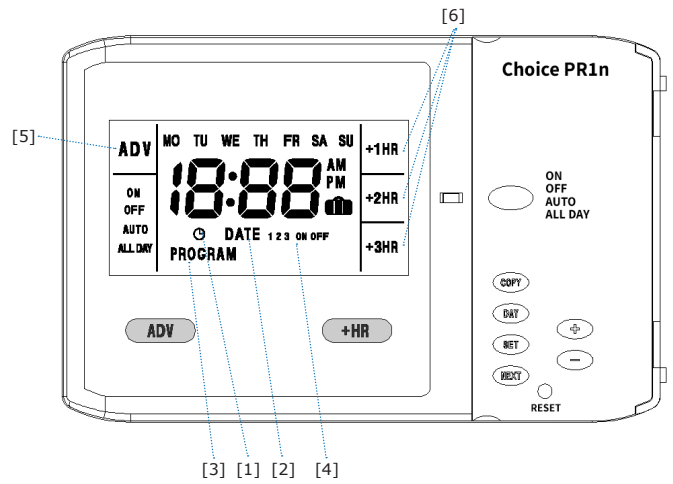

### Introduction

This programmer can automatically switch your central heating or hot water ON and OFF up to 3 times a day, at whatever times you choose. Timekeeping is maintained through power interruptions by a non-replaceable battery designed to last for the lifetime of the programmer. The clock is automatically put forward 1 hour at 1:00am on the last Sunday of March and back 1 hour at 2:00am on the last Sunday of October. The clock is factory pre-set to UK time and date, but you can alter the time setting if you wish.

During installation, the installer selects 24 hour, or 5 day/2day, or 7 day programming and 2 or 3 on/off periods per day, via a 4 position DIP switch on the back of the unit (see installation instructions).

**IMPORTANT:** These settings should only be changed by a qualified person. Contact your installer.

**IMPORTANT:** This programmer is not suitable for the switching of devices greater than 2 Amp rated per channel. (e.g. Not suitable for use as an immersion timer)

### Configuration

When setting time, date or changing programme times the first screen displayed indicates the configuration as set up by the installer. (See 'Setting The Time' section)

Configuration	Display
2 ON/OFF Pumped System	2PU
3 ON/OFF Pumped System	3PU

The 24 hour, or 5 day/2day, or 7 day programming option as set up by the installer can also be verified at this stage by how the Monday to Sunday indicators are displayed.

Programming Option	Mon to Sun Indicators flash
7 DAY	Mon to Sun individually shown
5/2 DAY	Mon to Fri together then Sat & Sun together
24 HOUR	Mon to Sun together shown

Now press any button to move to Setting the Time and Day.

### Built In Programme

For convenience, the programmer has a built in programme which will be satisfactory for many people, but which can be changed very easily (see section CHANGING PROGRAMME TIMES). Once the unit is powered up this built in programme will run.

If the user changes from the built in programme and wishes to return to it, then pressing the reset button with a non metallic pointed tool will return the unit to the built in / default programme

**NOTE:** Every time the reset is pressed, the time and date must be set again. See the sections 'Setting The Time & Setting The Date'

### Factory Programme Settings

2Pu	3Pu	Mon-Fri	Sat-Sun
1st ON	1st ON	6:00am	7:00am
1st OFF	1st OFF	8:30am	9:00am
-	2nd ON	12:00 noon	12:00 noon
-	2nd OFF	12:00 noon	12:00 noon
2nd ON	3rd ON	4:30pm	4:30pm
2nd OFF	3rd OFF	10:30pm	11:30pm

If the unit is installed as a 24 hour programmer the built in programme will be the same for each day (i.e. Sat-Sun be same as Mon-Fri above).

### Selecting Operating Mode

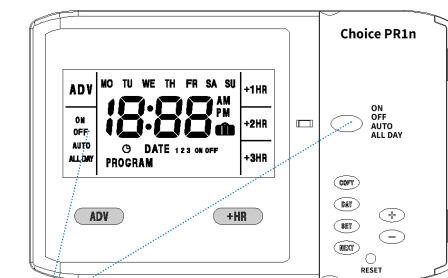

MODE	Description
ON	Central Heating and Hot Water is ON continuously
AUTO	Central Heating and Hot Water will be switched ON or OFF as programmed
ALL DAY	Central Heating and Hot Water will be switched ON only once each day between the first ON time and last OFF time
OFF	Central Heating and Hot Water is OFF continuously

### Setting The Time

- Press the **SET** button once. The configuration setting will appear on the screen.
- Press the **SET** button again. The clock icon [1] on the screen will flash.
- Press the +/- buttons to adjust the time. Time will change quicker if pressed continually.
- Press **SET** once to move on to setting the DATE or press multiple times to return to RUN mode.

### Setting The Date

- Press the **SET** button until the Y:XX (year) appears and the D (DATE) icon [2] flashes.
- Press the +/- button to set the year.
- Press **NEXT** button. M:XX appears (month).
- Press +/- button to set month.
- Press **NEXT** button. D:XX appears (Day).
- Press +/- button to set day.

You can review or edit the date you have set just by pressing **NEXT** button again and repeating the sequence above. To confirm the date and move on to PROGRAM mode press **SET** button once or press **SET** button multiple times to return to RUN mode.

### Changing Programme Times

The built in programmes can easily be changed to better suit your lifestyle.

To change the times:

- Press **SET** button until PROGRAM [3] flashes in the display and 1 ON [4] appears. This indicates the time shown on the display is the first ON time.
- By pressing the +/- buttons you can alter the ON time to the time you want.
- Press **NEXT** button, display will now show 1 OFF [4].
- By pressing the +/- buttons you can alter the OFF time to the time you want.
- Press **NEXT** button to access remaining ON/OFF periods and alter in same manner as above.
- To return to RUN mode, press the **SET** button until the display indicates RUN on the display

**NOTE:** Programming is in 10 minute segments.

### 7 Day Programmer Option

If the unit is installed as a 7 day programmer, the initial programme displayed will be for Monday.

You can go to any date of the week by pressing the **DAY** button repeatedly.

The ON/OFF times can be changed for each day as described above in the section "CHANGING PROGRAMME TIMES".

If you press the **COPY** button, the current programme will be copied onto the next day.

**NOTE:** it is not possible to copy Sunday to Monday.

### 5/2 Day Programmer Option

If the unit is installed as a 5 day/2 day programmer, the initial programme displayed will be for Monday to Friday.

Pressing the **DAY** button will take you to the programme for Saturday and Sunday.

The ON/OFF times can be changed for each day group as described above in the section "CHANGING PROGRAMME TIMES".

If you press the **COPY** button, the current programme will be copied onto the next day group.

### 24 Hour Programmer Option

If the unit is installed as a 24 hour programmer, the built in programme will be the same for each day. The **COPY** & **DAY** buttons have no affect if installed as a 24 hour programmer.

## Programming Notes

The unit will automatically return to normal running if a period of 30 seconds passes without any buttons being pressed.

For convenience, to allow for programmes to go past midnight, the programme day is from 03:00am to 02:50am the next day.

If a programme is required to run from 1.00 am to 8.00 am then 2 programmes must be used because it is not possible to programme through 2.50 am. (The programme should be split up into two sections; 3.00 am > 8.00 am and 1.00 am > 2.50 am).

## Reset

Press the reset button with a non-metallic pointed tool to restore the built in programme. As well as restoring the built in programme, it also resets the time to 12:00pm and the date to 01/01/2014. Initially the display shows all segments lit for a few seconds, but then will show the current configuration. See SETTING THE TIME section to continue.

As a safety feature after reset the unit will be in OFF operating mode. Reselect your required operating mode.

## Using Advance

The ADVANCE function allows the user to move to the next ON or OFF programme for a "one off" event, without having to change the programme or operating mode.

**Warning:** The ADVANCE function is only available when programme is in AUTO or ALL DAY operating modes.

### To advance Central Heating

Press the **ADV** button. This will turn the Central heating ON if it is in an OFF period and OFF if it is in an ON period. It will stay in this state until either **ADV** button is pressed again, or until a programmed ON/OFF period commences. The word ADV [5] will appear in the top left hand corner of the LCD.

## Using +HR Boost

Press the **+HR** button to make the desired selection with one, two or three hours extra heating [6] and cancel options offered.

**Warning:** The +HOUR function is only available when programme is in AUTO, ALL DAY or OFF operating modes.

If the Central heating operating mode is OFF, then it will switch on for the extra hours selected. If the Central heating mode is AUTO or ALL DAY, then during an OFF period, it will switch on for the extra hours selected. If during an ON period, then it will temporarily extend that programme by the number of hours selected, this is displayed on the right of the LCD display [6].

**NOTE:** If the programmer is in the OFF mode and then **+HR** button is pressed (+1 HR, + 2 HR, or + 3 HR) and the resulting time of the boost overlaps a START / ON time in the AUTO mode programme memory then the boost will disengage. If this happens simply press **+HR** button again and the boost will activate for the time period chosen.

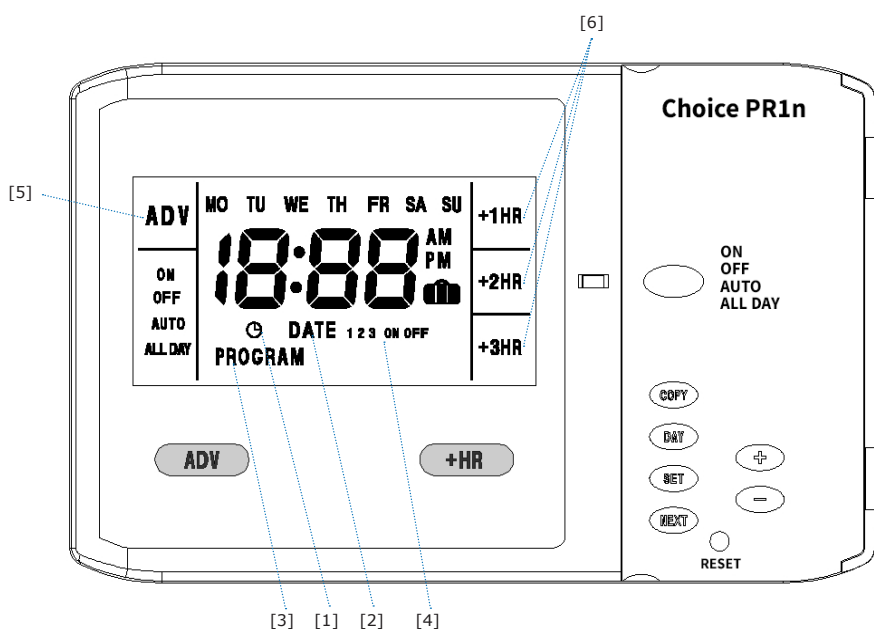

## Holiday Mode

The Holiday function allows the user to turn all channels to the OFF operating mode, for a settable amount of days from 01-99 days. During this function a suitcase icon will be displayed.

The number of days will decrease at midnight each day.

The +HR boost override can be used during a holiday period.

1. Press & Hold **DAY** button for 4 seconds to enter the holiday function, d:01 flashes.
2. Press +/- button to set the holiday days.
3. Press **DAY** button to activate.
4. Press & Hold **DAY** button for 4 seconds to cancel a holiday period.

**Warning:** The Holiday function is only available in AUTO, ALL DAY or ON operating modes.

## Power Interruption

In the event of a mains supply failure the screen will go blank but the back-up battery ensures that the programmer continues to keep the time and retain your stored programme. When power is restored, if there has been no change to the rear DIP switch, the programmer returns to its expected operating condition.

If the configuration setting on the rear DIP switch has been altered during the power interruption the screen will initially show the new configuration. And the appropriate factory default programme (see BUILT IN PROGRAMME section) will be installed. Press **SET** button to return to RUN mode.

If you have a problem or require any further information please contact us on: **01475 745131**

**Sangamo Limited**  
Industrial Estate, Port Glasgow,  
Renfrewshire, PA14 5XG

Tel **01475 745131**  
Fax: **01475 744567**  
Email: [enquiries@sangamo.co.uk](mailto:enquiries@sangamo.co.uk)  
Web: [www.sangamo.co.uk](http://www.sangamo.co.uk)



WEE/JH0069TY

## SERVICE AND WARRANTY

Your product is not user serviceable. **PLEASE DO NOT TRY TO DISMANTLE THE UNIT.**

This product is guaranteed by your supplier for 5 years from the date of manufacture. If it should become defective please contact your installer or supplier for a replacement unit or visit [www.sangamo.co.uk/returns](http://www.sangamo.co.uk/returns)

This product must meet Waste Electronic and Electrical Equipment Regulations (WEEE) for suitable environmental recycling, recovery and/or disposal. End of life products should be handled in line with local regulations. Alternatively return end of life product to Sangamo for correct disposal.

## CUSTOMER CARE POLICY

As part of Sangamo's continuous improvement program, the company operates a Customer Care policy. This means we welcome your comments and complaints, as it can help us to improve our services to you, our customer.

Due to our policy of continuous product improvement and development, the specifications in this guide may be subject to change without prior notice.