

MAGPRO-HD1

Intelligent analogue addressable fire alarm heat detector



1293

DoP No: 038

Tested by EVPU: N.B.1293

Distributor: Elite Security Products Ltd,
Unit 7 Target Park, Shawbank Road
Lakeside, Redditch B98 8YN, UK
<http://www.espuk.com>

Manufacturer: Teletek Electronics JSC
14A Srebarna Str, 1407 Sofia, Bulgaria

EN 54-5: 2000/ A1: 2002,
Detector Class A1/R, A2/S, B/S

Installation Instructions

ATTENTION: Read carefully this installation instruction before installing the device.
This manual is subject to change without notice errors and omissions accepted.

GENERAL DESCRIPTION:

MAGPRO-HD1 is an addressable temperature detector designed for use with ESP MAGPRO fire alarm panels. The detector is powered from the panel and can be controlled via its communication protocol.

The MAGPRO-HD1 is compatible with detector base MAGPRO-DB.

INSTALLATION

1. Select a suitable position for installation. *Note: Do not install the detector near to natural heat sources, e.g. above cookers, ovens or fire places.*

2. Mount the detector base to the required surface with suitable fixings.

3. Connect the detector base to the fire panel using the wiring diagram.

ATTENTION: Disconnect the loop power before installing the detector!

4. To activate the anti tamper lock option on the detector base carefully remove the small tooth shown in Fig2 using short nose snips.

5. To locate the detector onto the base align the line mark on the detector with the short line mark on the detector base. Rotate the detector clockwise until the short line mark on the detector coincides with the long mark on the base and a "click" is heard.

6. If removal of the detector is required after the detectors anti tamper lock function has been selected a small flat blade screwdriver should be inserted into the aperture on the side of the detector base. Lightly press with the screwdriver at the same time as rotating the detector head in a counter-clockwise direction.

TECHNICAL SPECIFICATIONS

Operating Voltage Range 15 - 32VDC (Nom. 27VDC)

Consumption in quiescent state, no communication . . . < 130µA@27VDC

Consumption in quiescent state, with communication . . . < 180µA@27VDC

Consumption in alarm state, with communication 6.5mA

Class, selectable from the control panel A1/R, A2/S, B/S

Protected area (in accordance with EN54-5) up 35m²

Installation height (in accordance with EN54-5) up 3,5m

Output in alarm state at terminal RI (terminals 4/ 1) . . . 7.5 mA (max)/ 7.5V

Wire Gauge for terminals 0.4mm² ÷ 2.0mm²

Relative humidity resistance (93 ± 3)% @ 40°C

Dimensions (incl. base) ø103mm, h 42mm

! Installation

IP30

-10°C ÷ +60°C

~110g
Without base

Indoor

Outdoor

>30cm >30cm

<7m - MAGPRO-HSD1
<5m - MAGPRO-HD1,
MAGPRO-SD1

Essential characteristics	Performance
Performance under fire conditions	Pass
Operational reliability	Pass
Durability of operational reliability and response delay: temperature resistance	Pass
Durability of operational reliability: humidity resistance	Pass
Durability of operational reliability: shock and vibration resistance	Pass
Durability of operational reliability: corrosion resistance	Pass
Durability of operational reliability: resistance to ingress	Pass

1 Base MAGPRO-DB

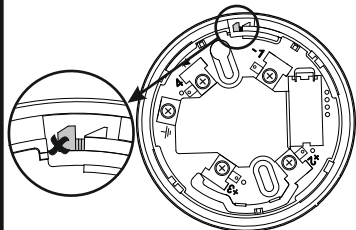

2

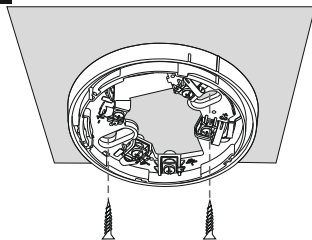

3 Address Programming



You may also program the address directly from the fire panel.

! Test and Maintenance

TESTING THE DETECTOR

1. Apply power to the detector.
2. Wait for 30 sec.
3. Introduce artificially generated heat directly beneath the detector. Within 8 sec the detector will enter into fire condition. Both LEDs will illuminate.
4. Power off the detector for 2 sec minimum. After resetting the detector will enter into duty mode and both LEDs will extinguish.

SERVICE MAINTENANCE

1. Inspection for visible physical damage - weekly.
2. Operational test in real conditions - monthly.
3. Check and clean dust contamination - six months.
4. Check and clean base and head contacts and connections - annually.

CLEANING AND MAINTENANCE

1. Remove the detector from its base.
2. Remove the inner protective cover - press the four clips (1) with a plain screwdriver gently down to unlock the cover from the detector's body.
3. Dismount the PCB from the supporting clips (2).
4. Clean the chamber.
5. Mount the PCB back to the detector's body - as a reference point use the side with a cut-out (3). Rotate the PCB until the cut-out coincides with the pin on the inner part from the detector body. Gently press the PCB down to fix in place.
6. Mount the inner protective cover - the mark with a rectangular shape (4) fits with the channel at the inner side of the detector's body and the contact plates on the protective cover. Press gently down until a click is heard.
7. Mount the detector back to its base and test for correct operation and LED indication.

4 Connection Diagram

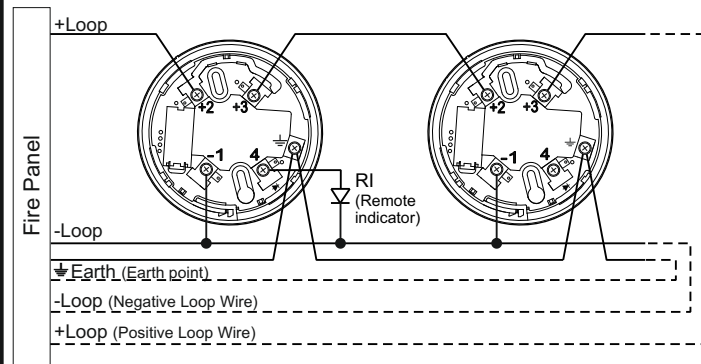

5

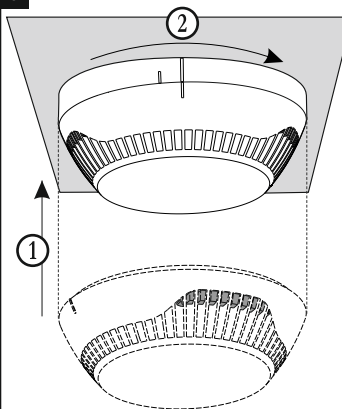

6 LED Indication

The LED indication can be enabled/ disabled from the control panel.

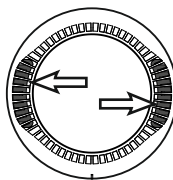

1. Blinking is enabled

Blinking	○ → 10 sec → ☀	OK
Light on	☀ → ☀	🔥
Light off	○ → ○	🔧

2. Blinking is disabled

Light on	☀ → ☀	🔥
Light off	○ → ○	🔧

7

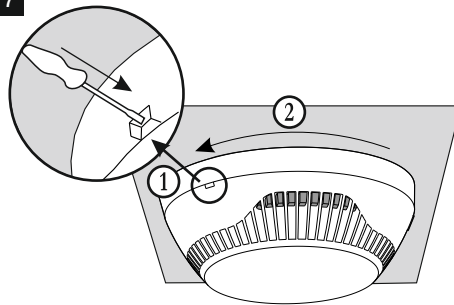

! Maintenance

