



# CSD212

COMBINED SENSOR DETECTOR  
OPTICAL SMOKE AND RATE-OF-RISE  
Installation Manual No: 18020743

CE 1293  
1293-CPD-0120

**ATTENTION:** This manual is subject to change without notice!  
Read carefully this installation instructions before installing the device!

## GENERAL DESCRIPTION:

The **CSD212** is a special kit for using in intruder alarm systems. The kit includes the combined sensor fire detector **CSD-2** and relay base **DB-12L/U** (12V).

## INSTALLATION

**1. Choose the proper place for installation** of the fire detector. Refer to the given installation instructions.

**Note:** Do not install the detector near sources of steam, condensation or smoke and close to natural heat sources.

**2. If you want to "lock" the detector to the base** remove the little "tooth" (with the triangle shape) and break the plastic key off the base. Keep the plastic key in safe place to be able to open the detector later.

**3. Mount the relay base** on the ceiling of the protected premises using fixings according the mounting surface.

**4. Connect the detector base** to the intruder alarm panel using the wiring diagram.

**ATTENTION: Disconnect the main power supply before installing the detector!**

**5. Insert the detector into the base** and rotate clockwise until it drops into place. Continue to rotate the detector until it locks to the base - a click is heard.

**6. If the detector has been locked to the base, when open it** for a service schedule maintenance and cleaning you have to use the plastic key. Light press with the plastic key into the base opening and at the same time rotate the detector head counter-clockwise.

**ATTENTION: To clean the wire mesh you have to remove the detector's PCB and then carefully to disassemble the smoke chamber from it. Clean the wire mesh and mount the chamber back on the PCB as observe the arrows - they have to coincide, then slightly press the chamber to the detector's PCB. Next you have to mount the PCB back to detector's plastic body. Find the color dot sticker on the PCB and orientate it to the mark on the plastic body (visible from the outside). The hole next to the color dot have to coincide with the pin on the plastic body. Gently press downwards to fix the PCB in place.**

## TESTING THE DETECTOR

**To test the detector use a smoke probe:**

1. Apply power to the detector.
2. Wait for 30 sec.
3. Exert influence on the fire detector by smoke generator (*Dispenser*) or by aerosol simulator of smoke to test the optical part; or use heat tester (*Cordless Heat Detector Tester or Heat Tester 110V>240V*) at distance of 20 cm to test the heat part. Within 8 sec the fire detector will enter in fire condition. Both LEDs will light up.
4. Power off the detector for 2 sec. minimum. After resetting the detector will enter in duty mode and the LEDs will light off.

## SERVICE MAINTENANCE

1. Inspection for visible physical damage - weekly.
2. Operational test in real conditions - monthly.
3. Check and clean dust contamination - six months.
4. Check and clean base and head contacts and connections - annually.

## TECHNICAL SPECIFICATIONS

Operating Voltage Range . . . . .	9 - 30 VDC (Nom.12/24VDC)
Average current consumption in quiescent state . . . . .	< 50µA
Alarm state current: . . . . .	18 mA / 9V; 29mA / 12V; 32mA/ 15V
Class (for the heat part, in accordance with EN54-5/7) . . . . .	A1/R
Protected area (in accordance with EN54-5/7) . . . . .	up 120m <sup>2</sup>
Installation height (in accordance with EN54-5/7) . . . . .	up 16m
Output in alarm state at terminal RI . . . . .	20mA (max)/ -3.3V (Towards terminals +IN /+OUT)
Degree of protection . . . . .	IP30
Wire Gauge for terminals . . . . .	0.4mm <sup>2</sup> ÷ 2.0mm <sup>2</sup>
Operational temperature range . . . . .	-10°C ÷ +60°C
Relative humidity resistance . . . . .	(93 ± 3)% @ 40°C
Dimensions (incl. base) . . . . .	ø102mm, h 48mm
Weight (incl. base) . . . . .	160g

! Base BD-12L/U

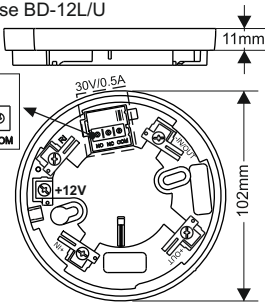

1

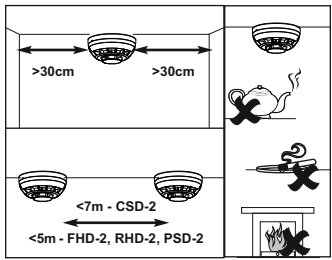

2

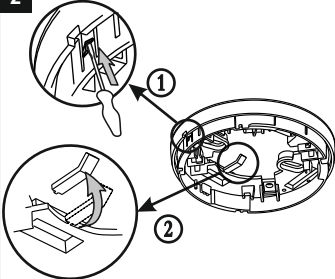

3

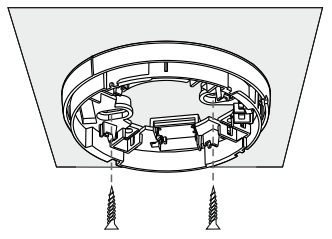

4

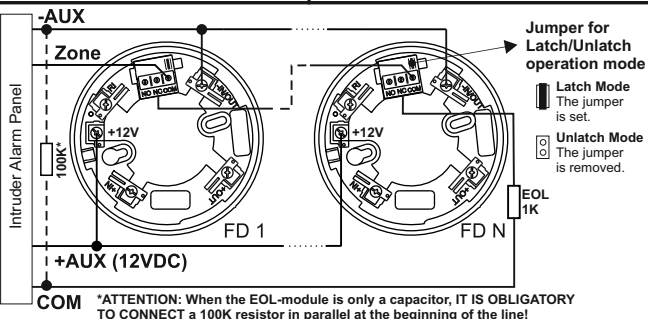

5

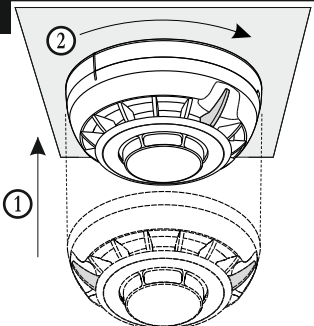

6

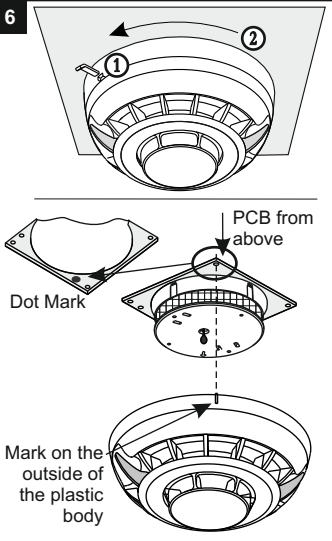

LED Indication

Blinking	○ → 8 sec → ☀	OK
Light on	☀ → ☀	🔥
Light off	○ → ○	🔧