

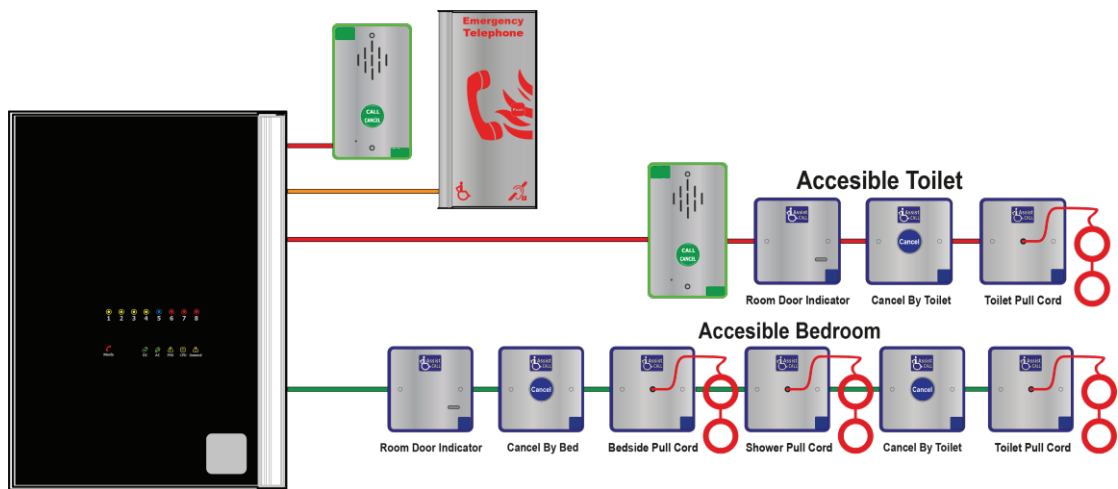

Beacon BMNETEX EVCS System Expander Panel



Installation and Commissioning Manual

Table of Contents

1	Introduction.....	3
1.1	What is an Emergency Voice Communication System?.....	3
1.2	Suitability.....	3
2	Product Overview.....	3
3	Important Safety Information.....	4
3.1	Unpacking the BMNETEX.....	4
4	Installation.....	5
4.1	Connecting the BMNETEX System Expander panel.....	5
4.2	Planning the Wiring.....	6
4.3	Cable and Wiring Guidance.....	6
4.3.1	Fire Telephone system.....	6
4.3.2	Disabled Refuge EVC System.....	6
4.3.3	Combined Systems.....	6
4.3.4	“Assist Call” Emergency Assistance Alarm Systems.....	6
4.4	Cabling methods.....	6
4.4.1	BMNETEX System Expander Panel Wiring.....	7
4.4.2	BMNET Master, BMNETEX System Expander Panel wiring in ring.....	7
4.4.3	Mains Connection.....	8
4.5	Battery Information.....	8
4.6	Outstation Connections.....	9
4.6.1	Type A outstation.....	9
4.6.2	Type B outstation.....	9
4.6.3	“Assist Call” BAKIT Accessible Toilet Kit.....	10
4.6.4	Enable Switch Input.....	10
4.7	BMNETEX Auxiliary Connections.....	10
4.8	Powering up procedure.....	10
4.9	Powering down procedure.....	11
5	Hardware configuration procedure.....	11
5.1	Exchange PCB Dipswitch Settings.....	11
6	Indications.....	12
6.1	Mode Indicator Summary.....	12
6.2	Power supply and CPU indicator Summary.....	12
6.3	Zone Indicator Summary.....	12
7	Commissioning procedure.....	13
8	Maintenance.....	13
9	Technical Specification.....	16

1 Introduction

1.1 What is an Emergency Voice Communication System

An Emergency Voice Communication System, or EVCS, is a system that allows voice communication in either direction between a central control point and a number of other points throughout a building or building complex, particularly in an emergency situation. The control points, or outstations by which they are more commonly referred, generally comprise of a Type A outstation, a Type B outstation, or a Type C Combined Type outstation. "Assist Call" emergency assistance alarm systems can also be incorporated into the EVCS.

EVCS is generally required in the following situations:

- In any building or sports or similar venue where there are disabled people, or people who may have difficulty negotiating the evacuation route.
- In buildings with phased evacuation and/or firefighting lifts where it facilitates secure communications for building managers, fire wardens, and attending fire officers.
- At sports venues and similar complexes, where it will assist stewards in controlling the evacuation of the area in an emergency.

The Beacon Emergency Voice Communications System (EVCS) is designed to fully comply with BS5839 Part 9:2021 for use as a Fire Telephone system, Disabled Refuge Call system or as a combined system when both Fire Telephones and Disabled Refuge Points are required.

1.2 Suitability

Fire telephone systems are recommended for all public buildings and multi-story buildings over four floors by BS9999.

Disabled Refuge systems are required in all buildings other than pure dwelling houses over one story. Refuge areas should be provided at each storey exit to every protected stairway as directed in Building Regulations Approved Document B1.

Emergency Assist Alarm Systems as recommended by BS8300 and Building Regulations Approved Document M, including the remote accept facility required.

2 Product Overview

The Beacon EVCS has been designed around a total network concept so all of the Beacon panels have inbuilt networking.

The system comprises 3 types of panel; Beacon BMNET touch screen master station (hereafter referred to as TMS), the Beacon BMNET 2 to 8 line master station (hereafter referred to as BMNET) and a Beacon expander panel (hereafter referred to as BMNETEX). For Beacon systems in excess of 8 lines a Beacon must be used as the master station, the system can then be expanded by the use of an BMNET or BMNETEX in blocks of 8 lines up to a maximum system capacity of 512 lines.

Additional BMNET panels can be used wherever indication and control is required, i.e. Fire Control rooms and building reception. These additional BMNET panels have the facility to filter the information that is displayed, so if there are several buildings with a BMNET in each building, the BMNET can be configured to only display/ answer EVCS calls from that building. The system also has the ability for **all** calls to be displayed /answered on a particular BMNET panel thus becoming the overall site master. This display filter can also be applied to "Assist Call" indications so panels can be configured to only display/acknowledge calls from "Assist Call" emergency assistance alarms. This display filtering works in exactly the same manner as for EVCS calls.

Each BMNET can be configured so information displayed during daytime is distinct from information displayed during night-time, thus allowing separate locations to handle daytime operations and night-time operations. The day/night timing applies across the entire network.

The Beacon BMNET panels are able to call individual outstations via a named directory list or by dialling the appropriate extension number for the desired outstation. In addition to this it is possible to call from one BMNET master station to another so communication between master stations is possible and control can be transferred between master stations.

3 Important Safety Information

This Equipment must only be installed and maintained by a suitably skilled and competent person.

This Equipment is defined as Class 1 in EN60065 (Low Voltage Directive) and must be EARTHED.



Caution

Warning

Warning

Warning

Warning



Indoor Use Only

Shock Hazard-

Isolate Before Opening

TO REDUCE THE RISK OF FIRE OR ELECTRIC SHOCK, DO NOT EXPOSE THIS UNIT TO RAIN OR MOISTURE

THIS UNIT MUST BE EARTHED

NO USER SERVICEABLE PARTS



Each BMNET and BMNETEX requires a 3A spur, returning to a breaker clearly marked “**EVCS DO NOT TURN OFF**”.

If the BMNET, BM2/4/8 and the BMNETEX are distributed around a site , it is essential that all panels are on the same mains phase, as they are classified TEN 230V. Powering from different phases can mean a 440V potential can be present in a panel during a major fault incident.



Anti-static handling guidelines

Make sure that electrostatic handling precautions are taken immediately before handling PCBs and other static sensitive components.

Before handling any static-sensitive items, operators should get rid of any electrostatic charge by touching a sound safety earth. Always handle PCBs by their sides and avoid touching any components.

3.1 Unpacking the Beacon BMNETEX

Remove the BMNETEX from its packing, and check the contents against the following list:

- BMNETEX System Expander Panel.
- Accessory pack with the following contents: -
 - 1 number 2.5mm AF Hex Key.
 - 8off 10K End of Line (EoL) Resistors.
 - Installation and Commissioning Manual (this document)

Use the 2.5mm AF Hex Key supplied to open the right-hand front cover.

Verify the following items are present:

- 4 number Line cards c/w 2-way line connector.
- 1 number 2-way Fault connector.
- 1 number 2 way In Use connector.
- 1 number 2- way Enable connector.
- 4 number 2-way Network connectors.
- 1 number 3-way mains connector.
- 1 number battery lead.

4 Installation

4.1 Connecting the BMNETEX

To comply with EMC (Electro Magnetic Compatibility) regulations and to reduce the risk of electrical interference in the system wiring, the use of fire-resistant screened cables is recommended throughout the installation.

All wiring should come into the enclosure via the knockouts provided and be fixed tidily to the relevant terminals.

Note that correct cable glanding is essential. Due regard should be paid to any system specifications which demand a certain cable type, providing it meets the appropriate national wiring regulations.

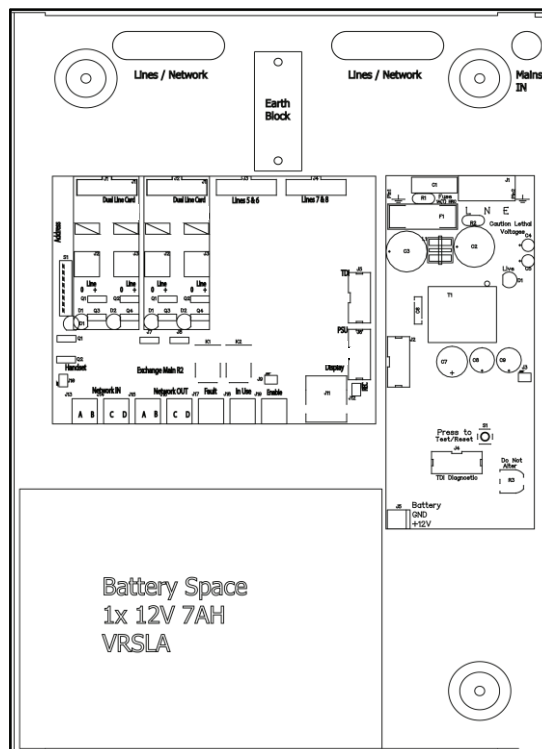

Prior to mounting the BMNETEX, it should be decided if the field wiring is to be run on the surface or concealed. There are 14 knockouts on the top and 2 slotted entries with a dedicated mains supply entry at the rear. If a knockout is removed by mistake, fill the hole with a good quality cable gland.

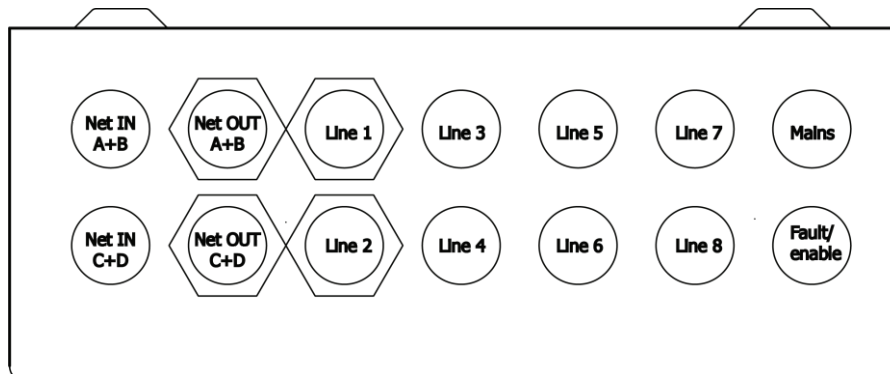

Unused knockouts must be left unopened to comply with the Low Voltage Directive. Accidentally knocked out holes should be blanked off.

The BMNETEX weighs 5kg with batteries, so care should be taken to securely mount the Station on stud walling.

4.2 Planning the Wiring

All system wiring should be installed to meet the appropriate parts of BS5839 Part9:2021 and BS 7671 (Wiring Regulations). Other national standards of installation should be adhered to where applicable.



Do not test wiring using an insulation tester (Megger) with any equipment connected, as the 500 Volt test voltage will destroy these devices.

You must observe local wiring regulations. Do not run SELV and LV cables in the same enclosure without adequate insulation between them.

4.3 Cable and Wiring Guidance

4.3.1 Fire Telephone system

Any system using Type A outstations must use enhanced grade cabling throughout for all wiring, including the mains supply to the BMNETEX System Expander Panel .

4.3.2 Disabled Refuge EVC System

For buildings less than 30m in height, or any building with sprinklers fitted, standard grade fire resistant cable may be used to wire Type B outstation and the mains supply to the Master Controller; if the planned evacuation will be completed in 30 minutes.

If the building is over 30m in height without sprinklers, or where the evacuation will take place over multiple stages exceeding 30 minutes, then enhanced grade cables must be used.

4.3.3 Combined Systems

For systems containing Type A, Type B or Type C outstations, shared cable such as network cables must be enhanced grade.

Cabling to Type A or Type C outstations must be in enhanced grade fire resistant cabling.

Individual spurs to Type B outstations can be wired in standard grade fire resistant cabling in accordance with the wiring guidelines already set out for disabled refuge systems.

4.3.4 "Assist Call" Emergency Assistance Alarm Systems

All installations must conform to Building Regulations Approved Document M and BS8300. The system is wired using 2 core cable, and the plates can be wired in any order.

4.4 Cabling methods

There are 3 cabling methods available:

- Connection to a Type A or Type C outstation: use 2 core enhanced grade fire resistant cable when extending a firefighting telephone system.
- Connection to a Type B outstation: use 2 core standard grade fire resistant cable when extending a disabled refuge system.
- Connection to an "Assist Call" system on a dedicated line requires 2 core 1mm CSA or above PVC sheathed.

4.4.1 BMNETEX System Expander Panel Wiring

Typical wiring for a BMNETEX system expander panel is shown in the schematic below.

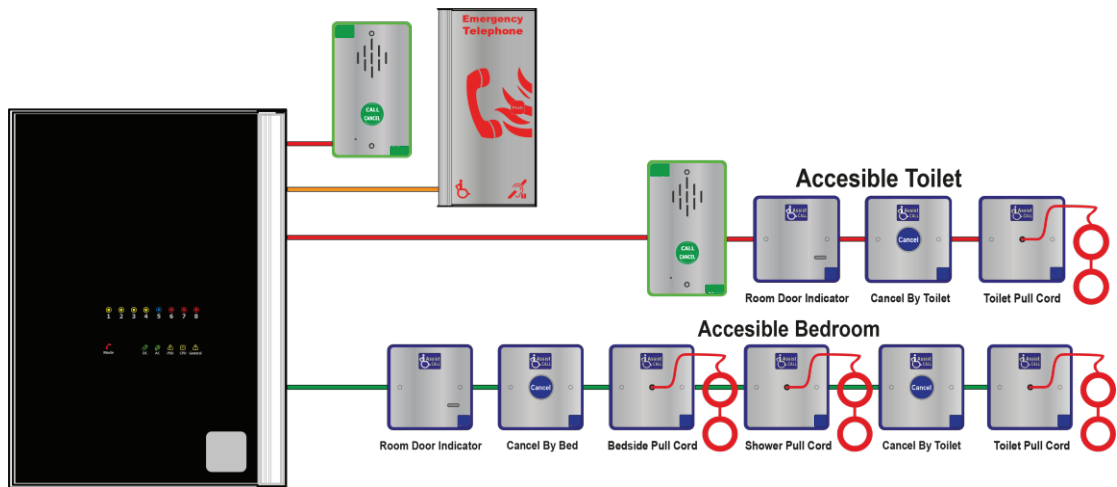

4.4.2 BMNET Master, BMNETEX System Expander Panel wiring in ring

If more than 8 lines are required then an BMNETEX will be required in addition to the BMNET, with the outstations shared between both the BMNET and the BMNETEX, the system has to be wired as a ring as shown in the schematic below. This ensures that the loss of any single cable will not affect the operation of more than one outstation.

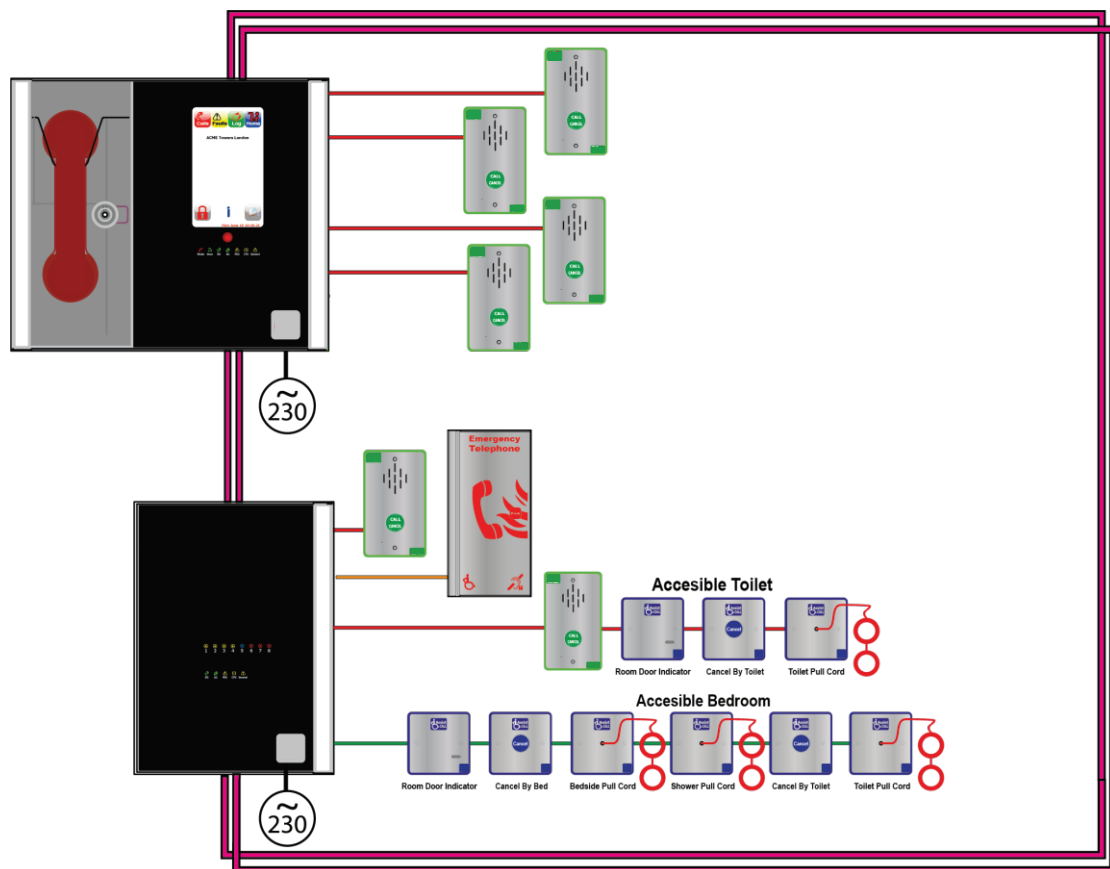

4.4.2.1 Network Wiring

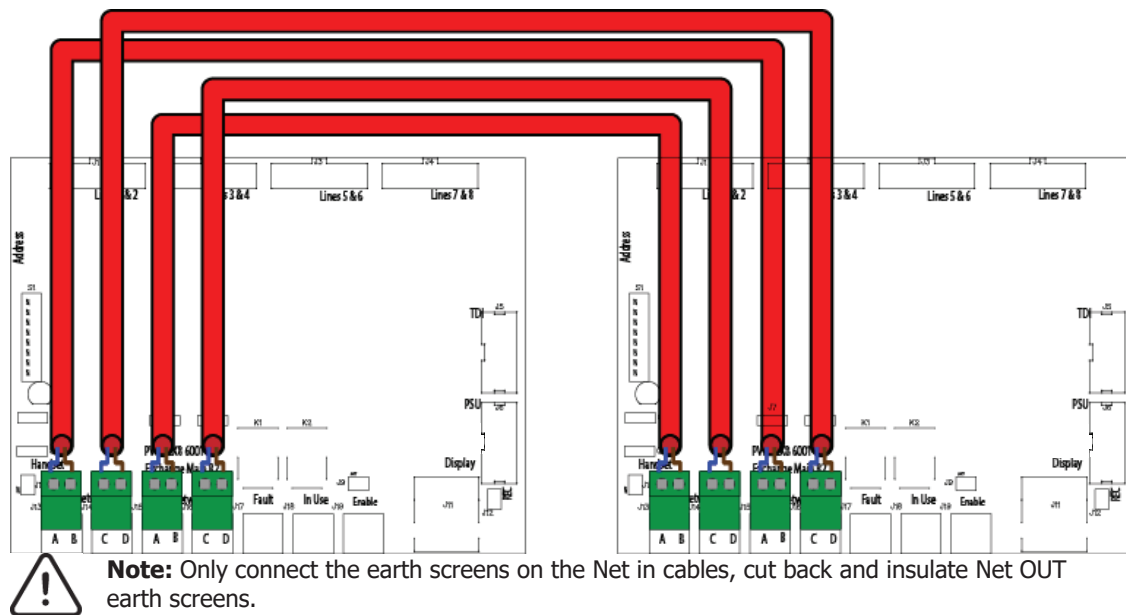

4.4.3 Mains Connection

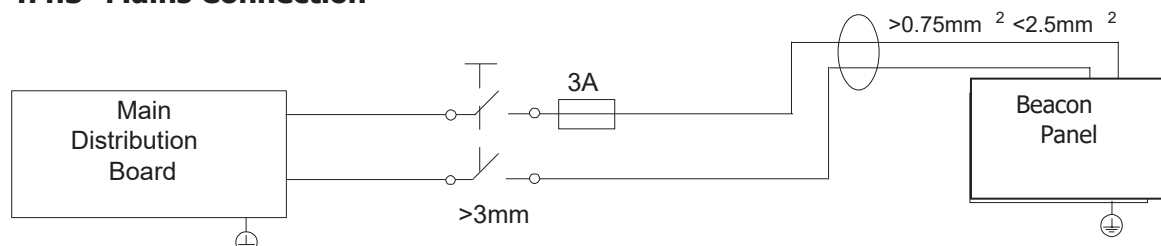

Each BMNET and BMNETEX requires a 3A spur, returning to a breaker clearly marked **“EVCS DO NOT TURN OFF”**.

If the BMNET, BM2/4/8 and the BMNETEX are distributed around a site, it is essential that all panels are on the same mains phase, as they are classified TEN 230V. Powering from different phases can mean a 440V potential can be present in a panel during a major fault incident.

4.5 Battery Information

In the event of mains failure BS5839 Part 9:2021 requires battery backup for 24 hours standby and 3 hours operation thereafter.

A BMNETEX requires **one number** 12V 7AH vent regulated sealed lead acid battery. The battery is not supplied with the BMNETEX. There is space for up to a 7AH battery.

	<p>Safety Information: Sealed Lead Acid batteries contain sulphuric acid which can cause burns if exposed to the skin. The low internal resistance of these batteries mean large currents will flow if they are accidentally short-circuited causing burns and a risk of fire. <i>Exercise caution when handling batteries.</i></p>
	<p>Power Up Procedure: Always apply mains power before connecting batteries. When connecting batteries, always connect the Positive (Red +) terminal first.</p>
	<p>Power Down Procedure Disconnect the batteries before removing the mains power. When disconnecting batteries, always remove the Negative (Black -) terminal first.</p>

4.6 Outstation Connections

The BMNET and BMNETEX are configured via the configuration spreadsheet contained on the Micro SD card supplied with the BMNET, for configuration (see section 6 of the BMNET manual).

The following devices are available on the system:

- Type A (fixed phone)
- Type B (hands-free refuge point)
- Type C "Combi" (combined Type A and Type B)
- Jack point
- "Assist Call" emergency assistance alarm system

For Type A, Type B, and Type C outstations, put the supplied end-of-line 10kΩ resistor into the end-of-line terminal in the outstation.

For Jack points, and the "Assist Call" system, put the supplied end-of-line 10kΩ resistor into the terminal in the last plate on the system.

4.6.1 Type A outstation

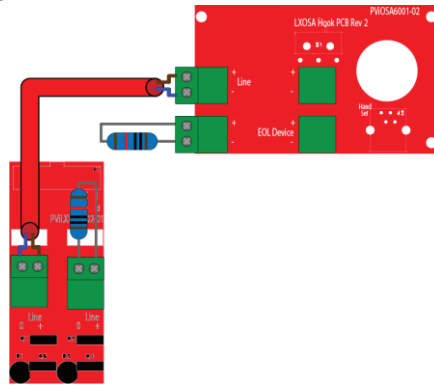

Note: The Earth screen should be sleeved and connected to the terminal block in the controller, and the earth stud in the Type A outstation.

4.6.2 Type B outstation

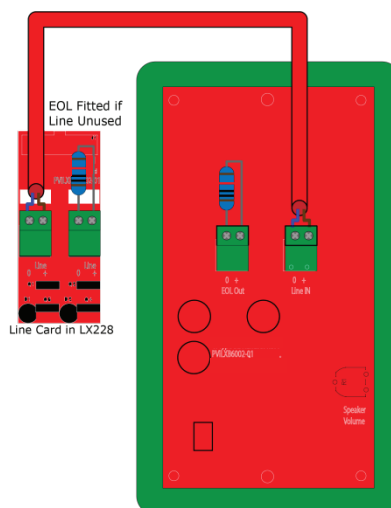

Note: The Earth screen should be sleeved and connected to the terminal block in the controller, and the earth connection in the metal back box (if a plastic back-box is used cut the earth back and insulate at the outstation).

4.6.3 "Assist Call" BAKIT Accessible Toilet Kit

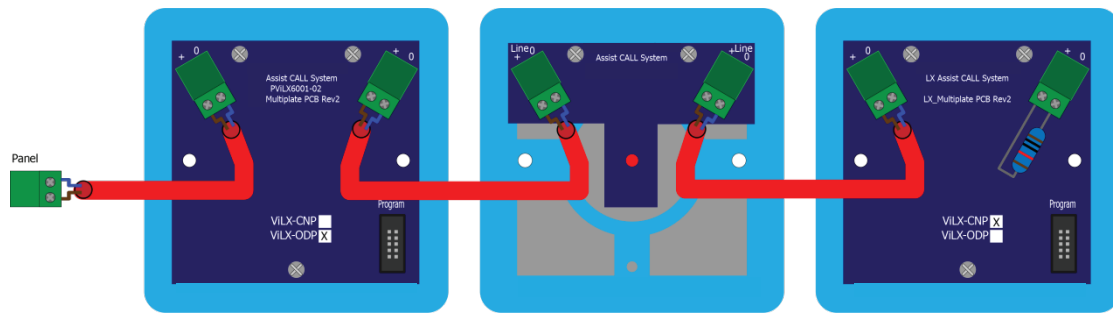

The "Assist Call" BAKIT comprises an Over door Indicator, a Pull Cord, and a Cancel Plate. The above order is a typical order; with the Over door Indicator, Pull Cord and the Cancel Plate connected as shown, the plates can be wired in any but the EOL resistor must be connected into the free terminal of the last plate.

4.6.4 Enable Switch Input



The Switch input is used for remote enabling or disabling of panels. The input is monitored, and expects a 470R resistor for activating (so a manual call point can be used). A 10K EOL resistor for the unit is supplied with the panel.

4.7 EX8 Auxiliary Connections

The EX8 has three auxiliary connections:

Fault is a normally CLOSED volt free relay (30V DC 1A) which OPENS on any fault on the network, including loss of power.

In Use is a normally OPEN volt free relay (30V DC 1A) connection. It Closes when any outstation is operated, local to the EX8 only, it is not programmable.

Enable is a normally CLOSED input and is required to operate the system, this is often connected to the fire alarm system. If Jumper J9 is in place, then no connection is required at the terminals. It is advised that this feature is not used as the system should always be available, not just during an evacuation.

If this function is used, then the removal of Jumper J9 and opening the **Enable** input, will not display incoming calls from Type B outstations only. Calls from Type B outstations automatically "time out" after approximately 30 minutes. Type A outstations and "Assist Call" emergency assistance alarm systems will continue to operate. If this feature is utilised, then the mode LED illuminates yellow after 30 seconds to show that the system is disabled.

Note. If the system is disabled, the master station can still make outgoing calls

If this function is used, it only requires connection with one panel on the network. If the **Enable** input is CLOSED on one panel, then all panels on the network are CLOSED. To disable Type B outstations, then the **Enable** input on all panels on the network must be OPEN.

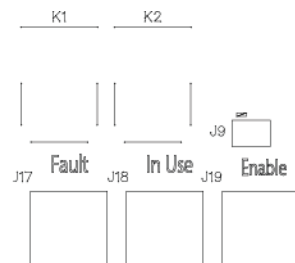

4.8 Powering up procedure

To power up the BMNETEX, carefully check all internal wiring before applying mains power to the BMNETEX. Once the BMNETEX is powered, the battery can be attached using the battery leads supplied. When attaching the battery, always attach the Positive (Red+) terminal first.

4.9 Powering down procedure

To power down the BMNETEX, first disconnect the battery. Always disconnect the Negative (Black -) terminal first. Once the battery leads have been disconnected, then remove mains power.

5 Hardware configuration procedure

The Beacon range of panels has in-built networking. This is described in the product overview section. Install the additional panel/station as per the relevant parts in the installation section 4. Any panels on the network must be wired as a ring (see 4.4.24.4.1). This is due to the ability for outstations to be wired from any panel therefore there is no loss of functionality due to cable faults as a ring provides redundancy.

Network connections used are Network Out and Network In, with Network In on one Station wired to Network Out on the other Station (A to A, B to B, C to C, and D to D).

The default network address setting for the is 2.

When adding an BMNETEX, it must have a unique network address, and must be included in the site configuration file (see section 6 of the BMNET manual).

If the site configuration is not updated the panel will not be seen by the rest of the network and importantly any outstations connected to that panel will not operate as they will not be seen by the rest of the network.

5.1 Exchange PCB Dipswitch Settings

The BMNETEX forms part of the Beacon network that can include other BMNET panels as well as BMNETEX Expander panels and BM2/4/8 panels. Each station on the network must have a unique network address. This address is set by the dipswitches on the Exchange PCB. The address is a binary number given by the positions of dip switches 1 to 6, with valid addresses lying between 1 and 64 inclusive.

Network address dipswitch setting						
Addr	1	2	3	4	5	6
1	1	0	0	0	0	0
2	0	1	0	0	0	0
3	1	1	0	0	0	0
4	0	0	1	0	0	0
5	1	0	1	0	0	0
6	0	1	1	0	0	0
7	1	1	1	0	0	0
8	0	0	0	1	0	0
9	1	0	0	1	0	0
10	0	1	0	1	0	0
11	1	1	0	1	0	0
12	0	0	1	1	0	0
13	1	0	1	1	0	0
14	0	1	1	1	0	0
15	1	1	1	1	0	0
16	0	0	0	0	1	0
17	1	0	0	0	1	0
18	0	1	0	0	1	0
19	1	1	0	0	1	0
20	0	0	1	0	1	0
21	1	0	1	0	1	0
22	0	1	1	0	1	0
23	1	1	1	0	1	0
24	0	0	0	1	1	0
25	1	0	0	1	1	0
26	0	1	0	1	1	0
27	1	1	0	1	1	0
28	0	0	1	1	1	0
29	1	0	1	1	1	0
30	0	1	1	1	1	0
31	1	1	1	1	1	0
32	0	0	0	0	0	1
33	1	0	0	0	0	1
34	0	1	0	0	0	1
35	1	1	0	0	0	1
36	0	0	1	0	0	1
37	1	0	1	0	0	1
38	0	1	1	0	0	1
39	1	1	1	0	0	1
40	0	0	0	1	0	1
41	1	0	0	1	0	1
42	0	1	0	1	0	1
43	1	1	0	1	0	1
44	0	0	1	1	0	1
45	1	0	1	1	0	1
46	0	1	1	1	0	1
47	1	1	1	1	0	1
48	0	0	0	0	1	1
49	1	0	0	0	1	1
50	0	1	0	0	1	1
51	1	1	0	0	1	1
52	0	0	1	0	1	1
53	1	0	1	0	1	1
54	0	1	1	0	1	1
55	1	1	1	0	1	1
56	0	0	0	1	1	1
57	1	0	0	1	1	1
58	0	1	0	1	1	1
59	1	1	0	1	1	1
60	0	0	1	1	1	1

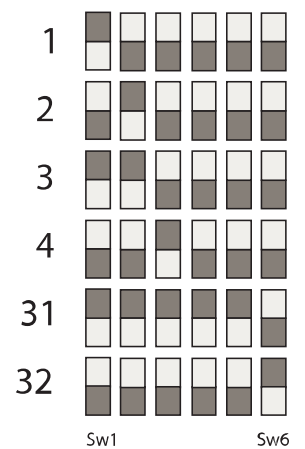

Dipswitch 7 & 8 Are reserved for future expansion.

29	1	0	1	1	1	0	61	1	0	1	1	1	1
30	0	1	1	1	1	0	62	0	1	1	1	1	1
31	1	1	1	1	1	0	63	1	1	1	1	1	1
32	0	0	0	0	0	1	64	0	0	0	0	0	0

6 Indications

6.1 Mode Indicator Summary

Mode	Description
Green solid	Normal state
Red solid	Outstation off hook
Blue solid	Assist call active
Yellow Solid	Type B disable function active (Enable jumper open)

6.2 Power supply and CPU indicator Summary

AC	DC	PSU	CPU	Description
✓				Mains OK
x		✓		Mains failure
✓	✓			Battery OK
✓	x	Flash		Battery open circuit
✓	x	✓		Battery short circuit
✓	Flash	✓		Battery high impedance
✓		✓	✓	PSU processor fail
✓			✓	Display or Exchange Processor Fault or Display-Exchange comms flt

✓ = LED illuminated

x = LED off

Flash= LED Flashing

Note: The general fault LED flashes on all fault conditions until accepted at the master station, when accepted the LED goes solid.

6.3 Zone Indicator Summary

Zone Indicator Status	Description
Slow flash red	Outgoing call
Fast flash red	Incoming call from type A outstation
Normal flash red	Incoming call from type B outstation
Normal flash green	Call connected to master handset
Normal flash green/red	Call on hold
Solid yellow	Line Short circuited
Slow flash yellow	Line card missing
Normal flash yellow	Line Open circuit or EOL missing
Fast flash yellow	Line Earth fault
Normal flash blue	Incoming Assist Call alarm
Solid blue	Assist call acknowledged

Note: The general fault LED flashes on all fault conditions until accepted at the master station, when accepted the LED goes solid.

7 Commissioning procedure

The commissioning should be carried out by a competent person who has a basic knowledge and understanding of the design and installation sections of BS5839 part 9:2021 and has access to the specification of the project.

The 500v insulation tests should have been carried out by the installer and the results made available to the commissioning engineer.

All cables should be correctly labelled.

Test field wiring and check for end-of-line 10KΩ resistor. Check cables are clear from any short or open circuits.

Connect cables into Line Cards.

Configure relevant dipperswitches for the network settings that may be required as per the set-up section in this manual.

Connect up network cabling, if network exists.

Power up the BMNET Master Station using mains only, fed from a 3A fuse fitted in an unswitched fused spur. The AC power indicator will be illuminated, and the DC power indicator is extinguished. The PSU fault and General fault indicators will be illuminated. There should be no line fault indicators illuminated.

Configure the system (see section 6 of BMNET manual)

If there are no line faults present, the battery may be connected. The DC power indicator will be illuminated, and the PSU fault and General fault indicators are extinguished when battery is connected.

If there are any line fault indicators illuminated, then the field wiring should be checked prior to the battery being connected.

Lift the master handset receiver and listen for a cadence tone.

Repeat the power up section for any BMNETEX Expander panels.

All outstations may be tested now, visit each outstation in turn and test that it is connected to the correct Master Station or Expander panel and perform an intelligibility test. This test should be conducted when the building has normal background noise levels. The intelligibility test requires two personnel.

Where Assist Call is fitted, all pull cords in each circuit should be tested, acknowledged at the panel, cancelled at the call location and the panel text checked. Ensure all controls and indicators operate correctly.

When all outstation tests are complete, network cable checks should be performed to ascertain correct operation by unplugging network cable to ensure the network is correctly fault monitoring and continues to work with a single cable fault.

When complete the log may be retrieved from MICRO SD card, saved as a spreadsheet and kept for record purposes.

8 Maintenance

It is a requirement of BS 5839-9:2021 that a maintenance agreement be in place for the EVCS. The maintenance schedule should be as follows:

Frequency	Test
Weekly	Test a different outstation on the system each week and make a call to the control. Repeat each week until all outstations and master stations are tested. Record these results in the site log. If more than one master station is present alternate weekly.
Biannually	Engineer call to check system operation, intelligibility, field strength of attached AFILS equipment and check battery health. Record results and any variations into the site Logbook Copy all log files from the on-board MICRO SD Card, and erase log directory before replacing card (to prevent out of memory errors)
Yearly	Engineer call to check system operation perform 100% outstation and master station operation, field strength of attached AFILS equipment and check battery health. Record results and any variations into the site Logbook
5 Yearly	In addition to Yearly tests replace all batteries and record in Logbook.

Notes

9 Technical Specification

Product Code	BMNETEX
Power Supply and Charger	
AC Input	230Vac+- 10% 50/60Hz
Internal power supply	12Vdc nominal
Supply and battery Protection	Monitored open, Short, Fuses Deep discharge, Short, Thermals
Temperature compensation	Yes
Battery information	1x 12V 7AH VRSLA
Mains fuse	1A HRC(T)
Battery fuse	Self Resetting PTC
Max charge current	500mA
Inputs	
Number of lines	8
Remote enable	Short to use
End of line monitoring	10KΩ 0.5 watt resistor
Relay outputs	
Number and type	2; Fault and In use, volt free 30Vdc 1A
Controls	
Number and type	None
Indication	
Number and type	3x PSU Status Indicators 1 x CPU Fault Indicators 1x General Fault Indicator 1x RGB Mode Indicator 8x RGB Line indicators
Enclosure Details	
Back box finish	RAL 7035 Grey
Dimensions (WxHxD)	220 x 300 x 95
Entries	14 knockouts top, 2x rear slots
Flush Cutout (WxHxD)	225 x 305 x 85



Elite Security Products UK, Unit 7 Target Park, Shawbank Road, Lakeside, Redditch, Worcestershire, B98 8YN
Tel +44(0)1527 515 150, Fax +44(0)1527 150 143; Email info@espuk.com
Registered in England Number Company Registration No: 02769392, VAT Registration GB614686525

For more product information please visit www.espuk.com
E&OE - Errors and omissions excepted.K21

