

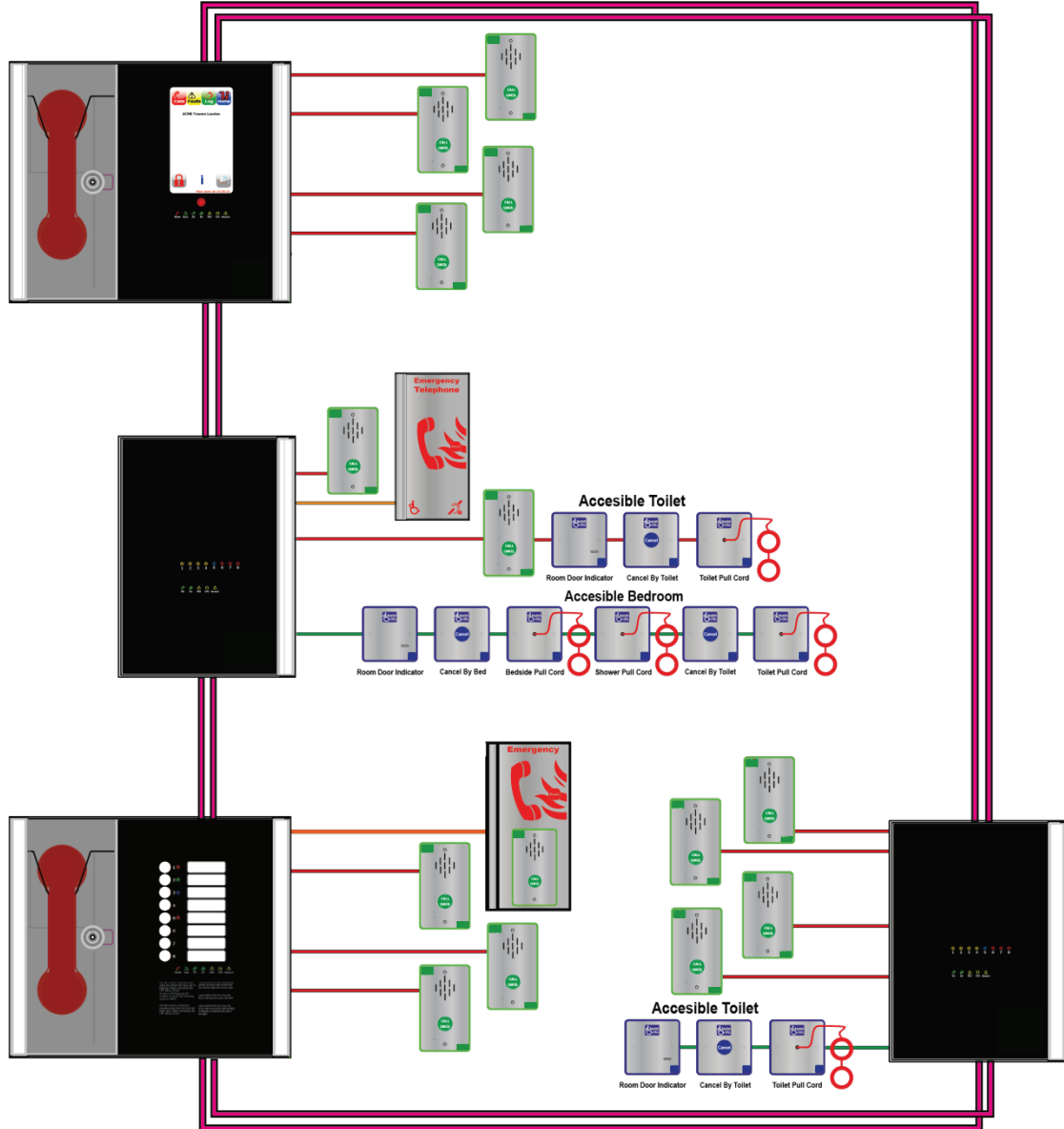

Beacon BMNET Master Station



Installation and Commissioning Manual

Table of Contents

1	Introduction	4
1.1	What is an Emergency Voice Communication System.....	4
1.2	Suitability.....	4
2	Product Overview.....	4
3	Important Safety Information.....	5
3.1	Unpacking the BMNET.....	6
4	Installation.....	7
4.1	Connecting the Beacon Master Station	7
4.2	Planning the Wiring.....	8
4.3	Cable and Wiring Guidance	8
4.3.1	Fire Telephone system	8
4.3.2	Disabled Refuge EVC System	8
4.3.3	Combined Systems	8
4.3.4	"Assist Call" Emergency Assistance Alarm Systems	8
4.3.5	"Assist Call" cabling methods	8
4.4	BMNET Master Station Wiring	8
4.4.1	BMNET Master, BMNETEX System Expander Panel wiring in ring	9
4.4.2	Mains Connection	10
4.5	Battery Information.....	10
4.6	Outstation Connections	11
4.6.1	Type A outstation	11
4.6.2	Type B outstation	11
4.6.3	"Assist Call" BAKIT Accessible Toilet Kit.....	12
4.6.4	Enable Switch Input.....	12
4.7	BMNET Auxiliary Connections	12
4.8	Powering up procedure	12
4.9	Powering down procedure	13
5	Hardware configuration procedure	13
5.1	Exchange PCB Diagram	13
5.2	Adding a Line Card.....	13
5.3	Removing a Line card.....	13
5.4	Adding a BEACON BMNETEX Master Station.....	13
5.5	Exchange PCB Dipswitch Settings	14
6	Configuration.....	15
6.1	Configuration file	15
6.2	Configuration Procedure	15
6.3	Configuration file sections.....	16
6.4	Project details	16
6.4.1	Project	16
6.4.2	Site name	16
6.4.3	Installer.....	16
6.4.4	Contact	16
6.4.5	Version details.....	16
6.5	Line details	17
6.5.1	Line	17
6.5.2	Used	17
6.5.3	Outstation text.....	17
6.5.4	Alarm text	17
6.5.5	Faults text	17
6.6	Panel details.....	18
6.6.1	Panel name.....	18
6.6.2	Panel type	18
6.6.3	Network settings	18
6.6.4	Day setting	18
6.6.5	Night setting	18
6.6.6	Fault setting.....	18
6.7	Custom logo.....	19
7	Operation.....	19
7.1	Touchscreen display operation	19
7.2	Navigation button operation.....	19
7.3	Header bar.....	19
7.4	Footer bar.....	19
7.5	Home screen.....	20
7.5.1	Home screen access level 1	20
7.5.2	Home screen access level 2	20
7.5.3	Home screen access level 3	20

7.6 PIN entry screen.....	20
7.7 Info screen	21
7.8 Clock screen.....	21
7.8.1 Day and night modes.....	21
7.9 Change PIN.....	21
7.9.1 Change Access Level 2 PIN.....	21
7.9.2 Change Access Level 3 PIN.....	22
7.10 Load configuration	22
7.11 Save configuration	22
7.12 Edit configuration.....	22
7.12.1 Project settings.....	22
7.12.2 Panel details.....	23
7.12.3 Address	23
7.12.4 Name	24
7.12.5 Net monitoring and Type.....	24
7.12.6 Lock Settings.....	24
7.12.7 Lock Action	24
7.13 Line details.....	25
7.13.1 Line monitoring	25
7.13.2 Outstation name.....	26
7.13.3 Alarm name	26
7.13.4 Fault name.....	26
7.14 Relay settings	26
7.14.1 Relay settings screen	26
7.14.2 Relay operation	27
7.15 Keyboard	28
7.16 Log screen	28
7.16.1 Log header	28
7.16.2 Log entries.....	28
7.16.3 Log navigation.....	28
7.16.4 Log filters	29
7.16.5 Log entries.....	29
7.16.6 Log entry icons for Call events	29
7.16.7 Log entry icons for Fault events	30
7.16.8 Log entry icons for System events	30
7.16.9 Calendar to select previous log file.....	31
7.17 Call screen	32
7.17.1 Call screen operation.....	32
7.17.2 Accepting incoming call	33
7.17.3 Place call on hold.....	33
7.17.4 Disconnect all calls.....	33
7.17.5 Call screen buttons	33
7.18 Directory screen.....	33
7.18.1 Directory screen operation	33
7.18.2 Placing an outgoing call to an outstation	34
7.18.3 Directory screen buttons.....	34
7.19 Dial screen	34
7.20 Alarms screen.....	35
7.20.1 Alarm screen operation	35
7.20.2 Acknowledge "Assist Call" alarm	35
7.21 Fault screen	36
7.21.1 Fault screen operation.....	36
7.21.2 Accepting faults.....	36
7.21.1 Fault information	36
7.21.2 Fault types.....	36
7.21.3 Panel faults.....	37
7.21.4 Line faults.....	37
8 Indications and Controls	38
8.1 Mode Indicator Summary.....	38
8.2 Power supply and CPU indicator Summary.....	38
9 Commissioning procedure	39
10 Maintenance	39
Technical Specification	40

1 Introduction

1.1 What is an Emergency Voice Communication System

An Emergency Voice Communication System, or EVCS, is a system that allows voice communication in either direction between a central control point and a number of other points throughout a building or building complex, particularly in an emergency situation. The control points, or outstations by which they are more commonly referred, generally comprise of a Type A outstation, a Type B outstation, or a Type C Combined Type outstation. "Assist Call" emergency assistance alarm systems can also be incorporated into the EVCS.

EVCS is generally required in the following situations:

- In any building or sports or similar venue where there are disabled people, or people who may have difficulty negotiating the evacuation route.
- In buildings with phased evacuation and/or firefighting lifts where it facilitates secure communications for building managers, fire wardens, and attending fire officers.
- At sports venues and similar complexes, where it will assist stewards in controlling the evacuation of the area in an emergency.

The Beacon Emergency Voice Communications System (EVCS) is designed to fully comply with BS5839 Part 9:2021 for use as a Fire Telephone system, Disabled Refuge Call system or as a combined system when both Fire Telephones and Disabled Refuge Points are required.

1.2 Suitability

Fire telephone systems are recommended for all public buildings and multi-story buildings over four floors by BS9999.

Disabled Refuge systems are required in all buildings other than pure dwelling houses over one story. Refuge areas should be provided at each storey exit to every protected stairway as directed in Building Regulations Approved Document B1.

Emergency Assist Alarm Systems as recommended by BS8300 and Building Regulations Approved Document M, including the remote accept facility required.

2 Product Overview

The Beacon EVCS has been designed around a total network concept so all of the Beacon panels have inbuilt networking.

The system comprises 3 types of panel; Beacon BMNET touch screen master station (hereafter referred to as BMNET), the Beacon BMNET 2 to 8 line master station (hereafter referred to as BMNET) and a Beacon expander panel (hereafter referred to as BMNETEX). For Beacon systems in excess of 8 lines a BMNET must be used as the master station, the system can then be expanded by the use of an BMNET or BMNETEX in blocks of 8 lines up to a maximum system capacity of 512 lines.

Additional BMNET panels can be used wherever indication and control is required, i.e. Fire Control rooms and building reception. These additional BMNET panels have the facility to filter the information that is displayed, so if there are several buildings with a BMNET in each building, the BMNET can be configured to only display/ answer EVCS calls from that building. The system also has the ability for **all** calls to be displayed /answered on a particular BMNET panel thus becoming the overall site master. This display filter can also be applied to "Assist Call" indications so panels can be configured to only display/acknowledge calls from "Assist Call" emergency assistance alarms. This display filtering works in exactly the same manner as for EVCS calls.

Each BMNET can be configured so information displayed during daytime is distinct from information displayed during night-time, thus allowing separate locations to handle daytime operations and night-time operations. The day/night timing applies across the entire network.

The Beacon BMNET panels are able to call individual outstations via a named directory list or by dialling the appropriate extension number for the desired outstation. In addition to this it is possible to call from one BMNET master station to another so communication between master stations is possible and control can be transferred between master stations.

The wiring is a ring and spur topology with outstations being wired on radial spurs from any master station or system expander panel. The BMNETEX and any BMNET or BM2/4/8 are wired in a ring network up to a max 64 . The BMNETEX would typically be sited in convenient locations close to the outstations i.e. risers or stairwells resulting in short vertical wiring runs. The BM2/4/8 can be used to provide local control of up to 8 lines within a building this can then report back to a BMNET which can provide overall control of an entire site.

In this way a very large system can be completed with a minimum of cabling coming back the master station via the network ring.

Additionally the "Assist Call" emergency assistance alarm system can either be connected to the same line with an outstation, or connected to a dedicated line. As each line is powered from the BMNETEX, the outstations and the "Assist Call" emergency assistance alarm system do not require a separate power supply unit. This has the additional benefit of each line being fully monitored and battery backed up.

3 Important Safety Information

This Equipment must only be installed and maintained by a suitably skilled and competent person.

This Equipment is defined as Class 1 in EN60065 (Low Voltage Directive) and must be EARTHED.



Caution

Warning

Warning

Warning

Warning



Indoor Use Only

Shock Hazard-

Isolate Before Opening

TO REDUCE THE RISK OF FIRE OR ELECTRIC SHOCK, DO NOT EXPOSE THIS UNIT TO RAIN OR MOISTURE

THIS UNIT MUST BE EARTHED

NO USER SERVICEABLE PARTS



Each BMNET and BMNETEX requires a 3A spur, returning to a breaker clearly marked "**EVCS DO NOT TURN OFF**".

If the BMNET, BM2/4/8 and the BMNETEX are distributed around a site , it is essential that all panels are on the same mains phase, as they are classified TEN 230V. Powering from different phases can mean a 440V potential can be present in a panel during a major fault incident.



Anti-static handling guidelines

Make sure that electrostatic handling precautions are taken immediately before handling PCBs and other static sensitive components.

Before handling any static-sensitive items, operators should get rid of any electrostatic charge by touching a sound safety earth. Always handle PCBs by their sides and avoid touching any components.

3.1 Unpacking the BMNET

Remove the BMNET from its packing, and check the contents against the following list:

- BMNET Master Station.
- Installation & maintenance manual (this document).
- User Guide & logbook.
- Accessory pack with the following contents:-
 - 1 number 2.5mm AF Hex Key.
 - 1 number Battery Lead.
 - End-of-Line 10k Ω Resistors, 2 per Line Card
 - USB Micro SD Card reader
 - Door Lock Key

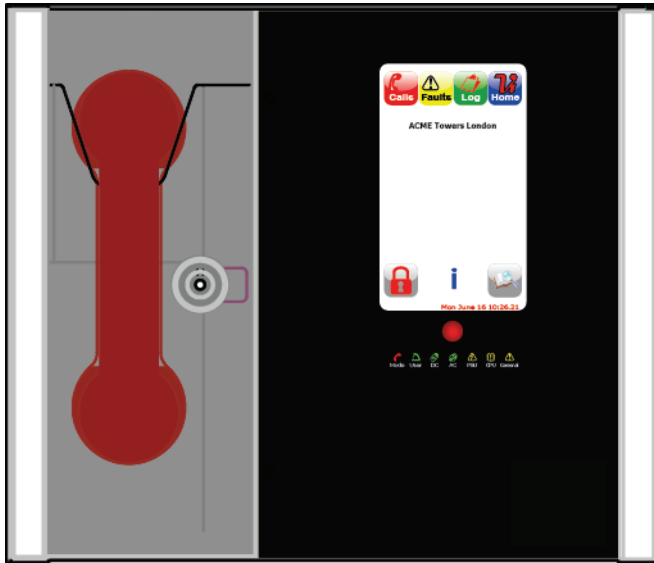

Use the 2.5mm AF Hex Key supplied to open the right hand front cover.

Verify the following items are present:

- 4 number Line cards.
- 1 number 2 way Fault connector.
- 1 number 2 way In Use connector.
- 1 number 2 way Enable connector.
- 4 number 2 way Network connectors.
- 1 number 3 way mains connector.

If there are any items missing, please contact your supplier or ESPUK

4 Installation

4.1 Connecting the Beacon BMNET Master Station

To comply with EMC (Electro Magnetic Compatibility) regulations and to reduce the risk of electrical interference in the system wiring, the use of fire-resistant screened cables is recommended throughout the installation.

All wiring should come into the enclosure via the knockouts provided, and be fixed tidily to the relevant terminals.

Note that correct cable glanding is essential. Due regard should be paid to any system specifications which demand a certain cable type, providing it meets the appropriate national wiring regulations.

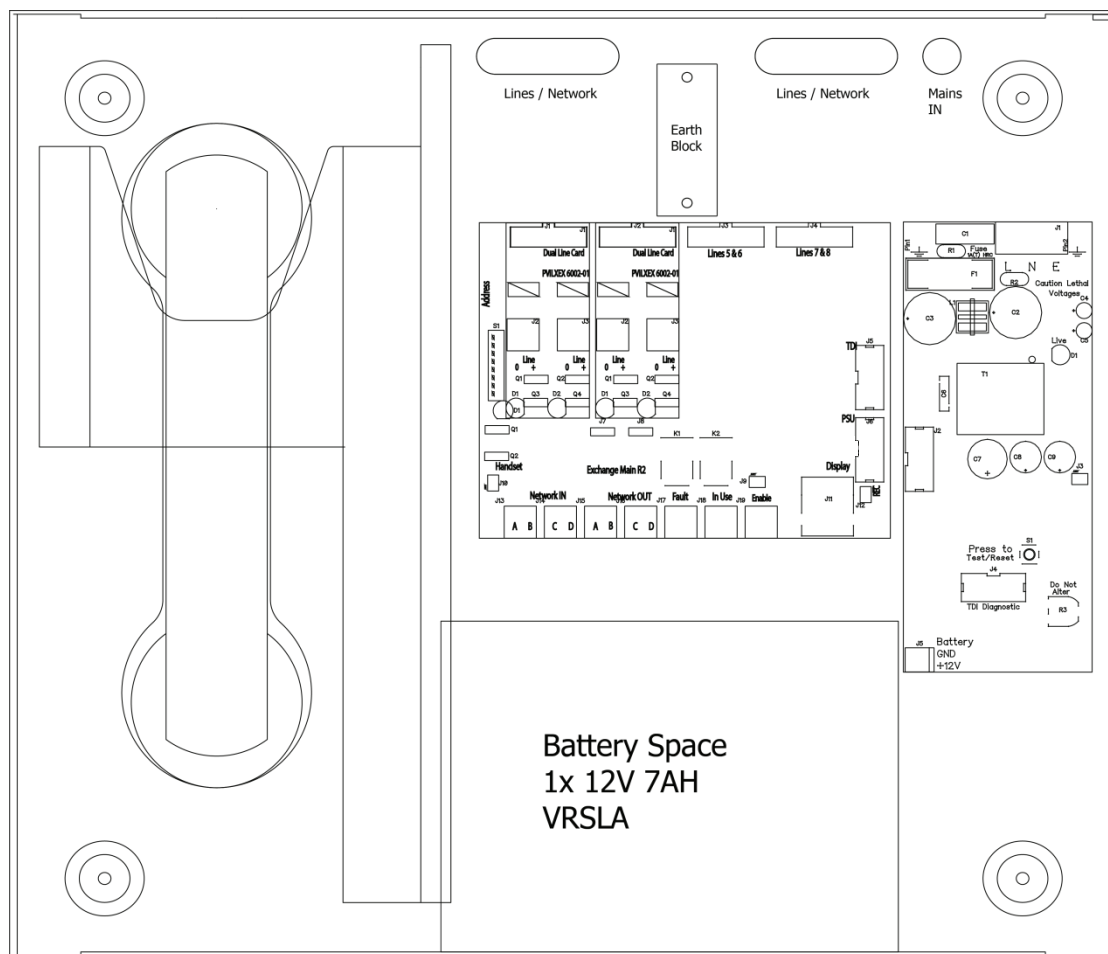

Prior to mounting the BMNET it should be decided if the field wiring is to be run on the surface or concealed. There are 14 knockouts on the top and 2 slotted entries with a dedicated mains supply entry at the rear. If a knockout is removed by mistake, fill the hole with a good quality cable gland.

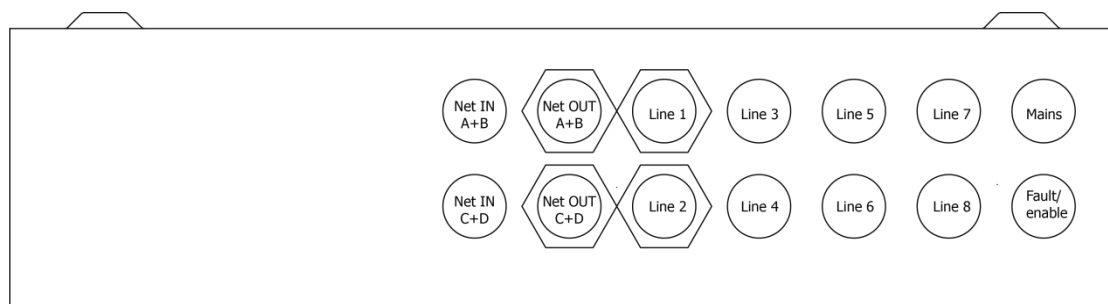

Unused knockouts must be left unopened to comply with the Low Voltage Directive. Accidentally knocked out holes should be blanked off.

The BMNET Master Station weighs 6kg with batteries, so care should be taken to securely mount the Station on stud walling.

4.2 Planning the Wiring

All system wiring should be installed to meet the appropriate parts of BS5839 Part9:2021 and BS 7671 (Wiring Regulations). Other national standards of installation should be adhered to where applicable.



Do not test wiring using an insulation tester (Megger) with any equipment connected, as the 500 Volt test voltage will destroy these devices.

You must observe local wiring regulations. Do not run SELV and LV cables in the same enclosure without adequate insulation between them.

4.3 Cable and Wiring Guidance

4.3.1 Fire Telephone system

Any system using Type A outstations must use enhanced grade cabling throughout for all wiring, including the mains supply to the BMNET/BMNETEX

4.3.2 Disabled Refuge EVC System

For buildings less than 30m in height, or any building with sprinklers fitted, and the planned evacuation will be completed within 30 minutes, then standard grade fire resistant cable may be used to wire Type B outstations and the mains supply to the BMNET/BMNETEX

If the building is over 30m in height without sprinklers, or where the planned evacuation will take place over multiple stages exceeding 30 minutes, then enhanced grade cables must be used.

4.3.3 Combined Systems

For systems containing Type A, Type B or Type C outstations, shared cable such as network cables must be enhanced grade.

Cabling to Type A or Type C outstations must be in enhanced grade fire resistant cabling. Individual spurs to Type B outstations can be wired in standard grade fire resistant cabling in accordance with the wiring guidelines already set out for disabled refuge systems.

4.3.4 "Assist Call" Emergency Assistance Alarm Systems

All installations must conform to Building Regulations Approved Document M and BS8300. The "Assist Call" is wired using 2-core cable, and the "Assist Call" plates can be wired in any order.

4.3.5 "Assist Call" cabling methods

There are two ways to integrate Assist call systems into the EVCS panels as shown below:

- Connection to a Type B outstation: use 2 core standard grade fire resistant cable, connecting to the EOL out connection of the type B outstation and placing the end of line resistor in the last "Assist Call" device on the line.
- Connecting an "Assist Call" system on to a dedicated line: requires 2 core 1mm CSA or above LSF sheathed. The maximum conductor resistance is 5 ohm per leg for proper operation. The end of line is placed in the last "Assist Call" device on the line for ease of fault finding.

Beacon BMNET Master Station Wiring

Typical wiring for a BMNET

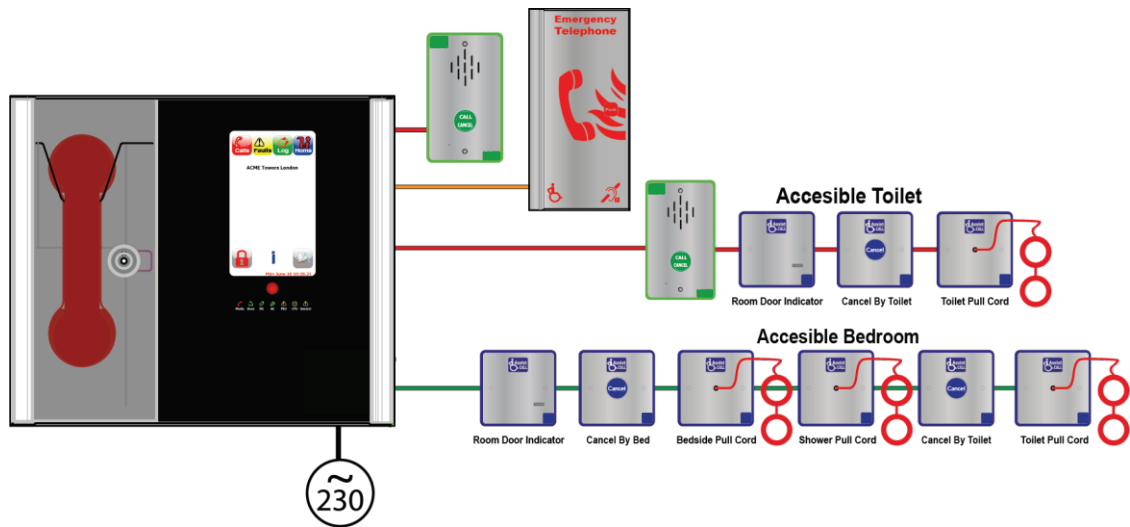

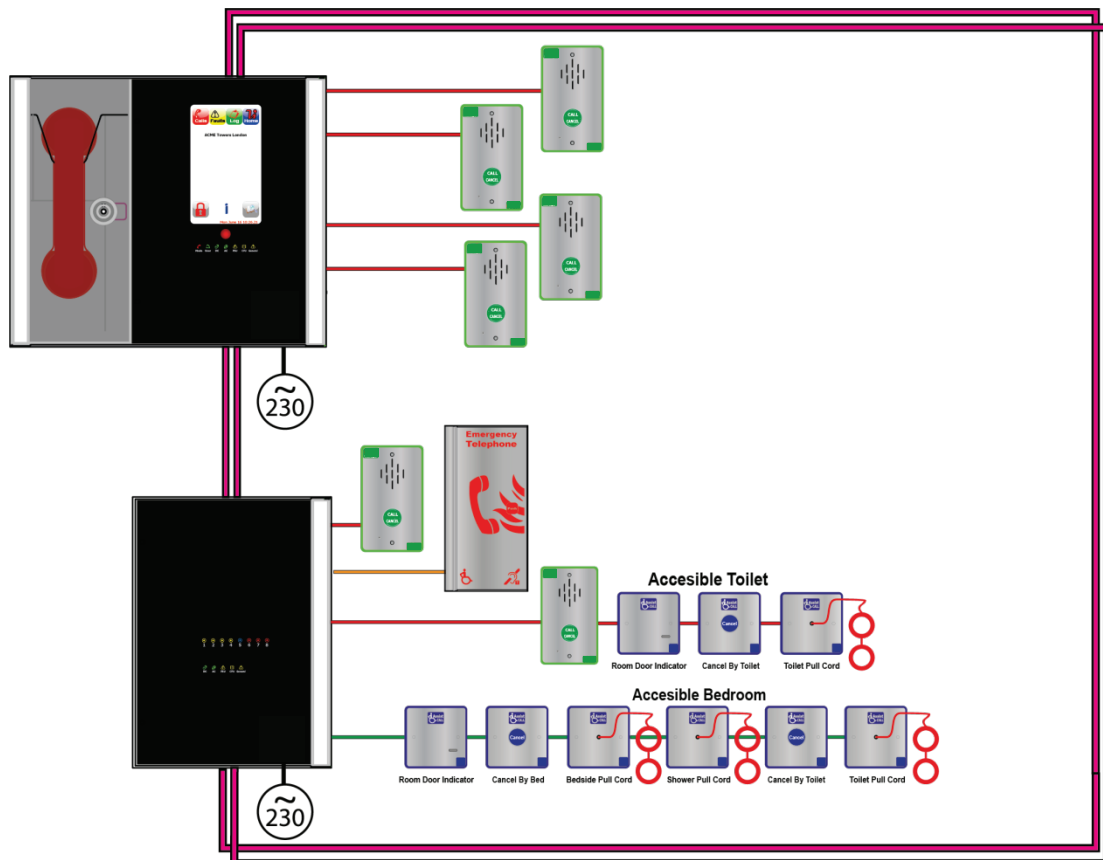

4.3.6 BMNET Master ,BMNETEX System Expander Panel Wiring Ring

If more than 8 lines are required then an BMNETEX will be required in addition to the TMS, with the outstations shared between both the BMNET and the BMNETEX. The system has to be wired as a ring as shown in the schematic below. This ensures that the loss of any single cable will not affect the operation of more than one outstation.

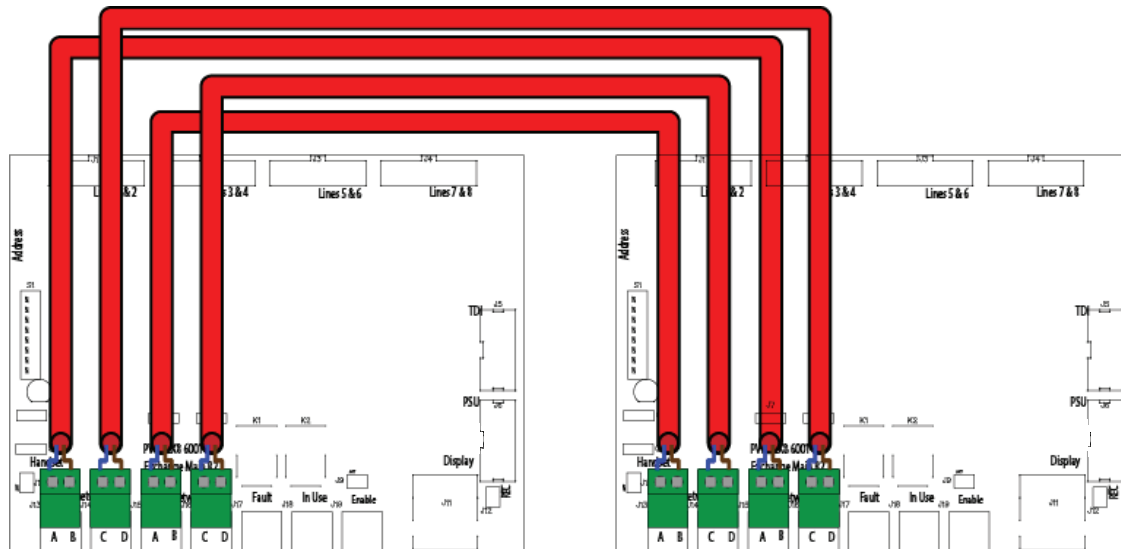

4.3.6.1 Network Wiring



 **Note:** Only connect the earth screens on the Net in cables, cut back and insulate Net OUT earth screens.

4.3.7 Mains Connection

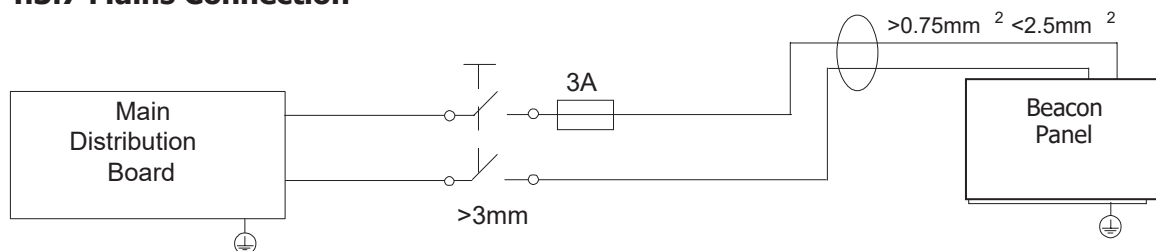

Each BMNET, BMNETEX, and BM2/4/8panel requires a 3A spur, returning to a breaker clearly marked **“EVCS DO NOT TURN OFF”**

If there are BMNET, BMNETEX, and BM2/4/8panels distributed around a site, it is essential that all panels are on the same mains phase, as they are classified TEN 230V. Powering from different phases can mean a 440V potential can be present in a panel during a major fault incident.

4.4 Battery Information

In the event of mains failure BS5839 Part 9:2021 requires battery backup for 24 hours standby and 3 hours operation thereafter.

A Beacon BMNET requires **one number** 12V 7Ah vent regulated sealed lead acid battery. The battery is not supplied with the Beacon BMNET.

	<p>Safety Information: Sealed Lead Acid batteries contain sulphuric acid which can cause burns if exposed to the skin. The low internal resistance of these batteries mean large currents will flow if they are accidentally short circuited causing burns and a risk of fire. <i>Exercise caution when handling batteries.</i></p> <p>Power Up Procedure: Always apply mains power before connecting batteries. When connecting batteries, always connect the Positive (Red +) terminal first.</p> <p>Power Down Procedure Disconnect the batteries before removing the mains power. When disconnecting batteries, always remove the Negative (Black -) terminal first.</p>
-------------------------------------------------------------------------------------	---------------------------------------------------------------------------------------------------------------------------------------------------------------------------------------------------------------------------------------------------------------------------------------------------------------------------------------------------------------------------------------------------------------------------------------------------------------------------------------------------------------------------------------------------------------------------------------------------------------------------------------------------------------------------------------------------------------------------

4.5 Outstation Connections

The BMNET and BMNETEX are configured via the configuration spreadsheet contained on the Micro SD card supplied with the BMNET, for configuration (see 6).

The following devices are available on the system:

- Type A (fixed phone)
- Type B (hands-free refuge point)
- Type C "Combi" (combined Type A and Type B)
- Jack point
- "Assist Call" emergency assistance alarm system

For Type A, Type B, and Type C outstations, put the supplied end-of-line 10kΩ resistor into the end-of-line terminal in the outstation.

For Jack points, and the "Assist Call" system, put the supplied end-of-line 10kΩ resistor into the terminal in the last plate on the system.

4.5.1 Type A outstation

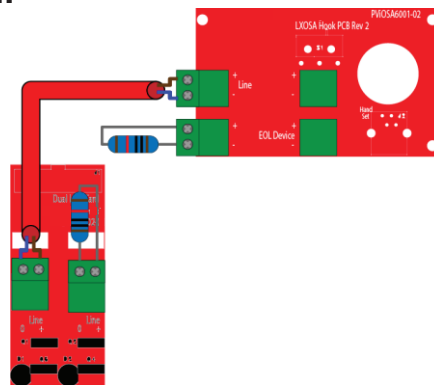

Note: The Earth screen should be sleeved and connected to the terminal block in the controller, and the earth stud in the Type A outstation.

4.5.2 Type B outstation

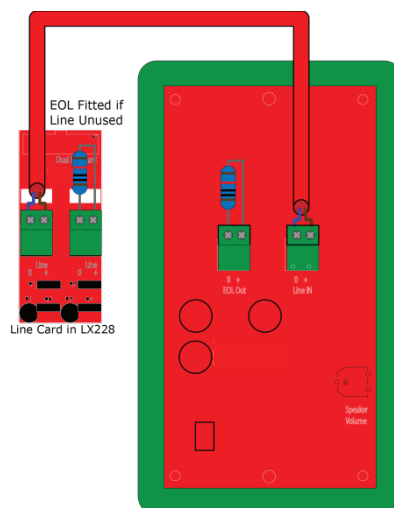

Note: The Earth screen should be sleeved and connected to the terminal block in the controller, and the earth connection in the metal back box (if a plastic back-box is used cut the earth back and insulate at the outstation).

4.5.3 "Assist Call" BAKIT Accessible Toilet Kit

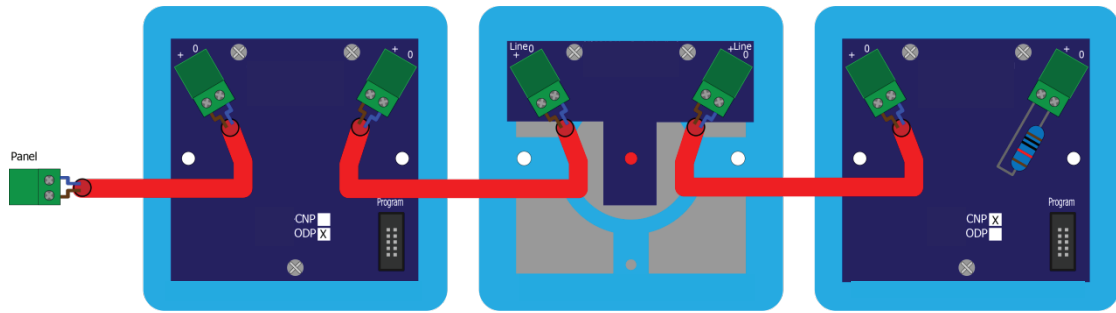

The "Assist Call" BAKIT comprises an Over door Indicator, a Pull Cord, and a Cancel Plate. The above order is a typical order; with the Over door Indicator, Pull Cord and the Cancel Plate connected as shown, but the plates can be wired in any order as long as the EOL resistor goes into the free terminal of the last plate.

4.5.4 Enable Switch Input



The Switch input is used for remote enabling or disabling of panels. The input is monitored, and expects a 470R resistor for activating (so a manual call point can be used). A 10K EOL resistor for the unit is supplied with the panel.

4.6 BMNET Auxiliary Connections

The BMNET has three auxiliary connections

Fault is a normally CLOSED volt free relay (30V DC 1A) which OPENS on any fault on the network, including loss of power.

In Use is a normally OPEN volt free relay (30V DC 1A) connection. The relay CLOSSES when configured to do so by the TMS (see 7.14.1), usually when an outstation on the network is operated.

Enable is a normally CLOSED input, and is required to operate the system, this is often connected to the fire alarm system. If Jumper J9 is in place, then no connection is required at the terminals. It is advised that this feature is not used as the system should always be available, not just during an evacuation.

If this function is used, then the removal of Jumper J9 and opening the **Enable** input, will not display incoming calls from Type B outstations only. Calls from Type B outstations automatically "time out" after approximately 30 minutes. Type A outstations and "Assist Call" emergency assistance alarm systems will continue to operate. If this feature is utilised, then the mode LED illuminates yellow after 30 seconds to show that the system is disabled.

Note. If the system is disabled, the master station can still make outgoing calls

If this function is used, it only requires connection with one panel on the network. If the **Enable** input is CLOSED on one panel, then all panels on the network are CLOSED. To disable Type B outstations, then the **Enable** input on all panels on the network must be OPEN.

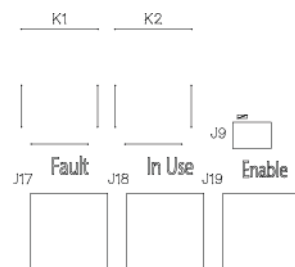

4.7 Powering up procedure

Before powering up the BMNET/BMNETEX, carefully check all internal wiring.

To power up the BMNET/BMNETEX:

1. Apply mains power first.
2. Connect the battery using the battery leads supplied. Always connect the Positive (Red+) terminal first before connecting the Negative (Black -) terminal.

4.8 Powering down procedure

To power down the BMNET:

1. Disconnect the battery. Always disconnect the Negative (Black -) terminal first, before disconnecting the Positive (Red +) terminal.
2. Remove mains power.

5 Hardware configuration procedure

5.1 Exchange PCB Diagram

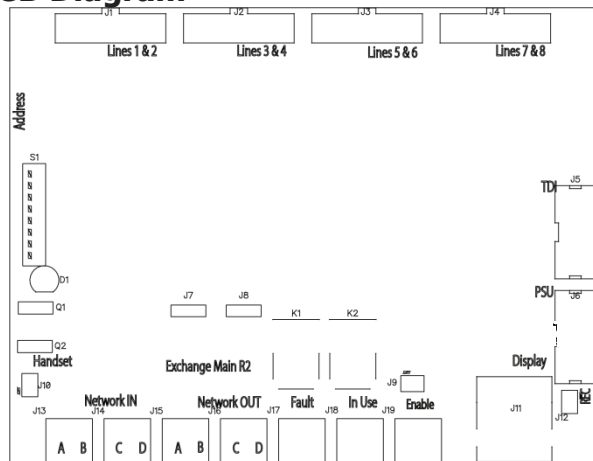

5.2 Adding a Line Card

Before adding a Line Card, ensure that the BMNET is not powered. If the BMNET is powered, then power down the BMNET (see 4.8).

To fit the Line Card:

1. Place Line Card in the next available space on the Exchange PCB and secure using the supplied screw.
2. Remove a terminal from the Line Card for each outstation to be fitted.
3. Connect the field wiring for the outstation to the terminal.
4. Push the terminal into the correct position on the Line Card.
5. Update the site configuration (see 6.2).

Once the Line Card is securely fitted, power up the TMS (see 4.7).

5.3 Removing a Line card

Before removing a Line Card, ensure that the BMNET is not powered. If the BMNET is powered, then power down the BMNET (see 4.8.1).

To remove the Line Card:

1. Remove all terminals from the Line Card that are wired to an outstation.
2. Remove screw securing the Line Card.
3. Remove Line Card from Exchange PCB.
4. Update the site configuration (see 6.2).

Once the Line Card has been removed, the BMNET may be powered (see 4.7).

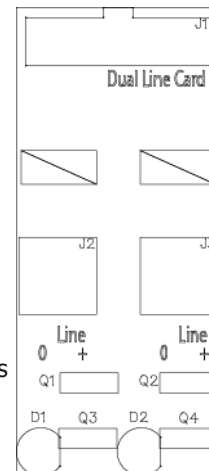

5.4 Adding a BMNET Master Station

Install the BMNET panel as per the relevant parts in the installation section 4.

The Beacon network can consist of BMNET, BMNETEX and BM2/4/8 panels. Each BMNET, BMNETEX, and BM2/4/8 panel has in-built networking that allows each panel to be connected to the Beacon network. The panel added to the network must be wired as a ring (see 4.3.6 and 4.3.6). This is due to the ability for outstations to be wired from any panel therefore there is no loss of functionality due to cable faults as a ring provides redundancy.

Network connections used are Network Out and Network In, with Network In on one Station wired to Network Out on the other Station (A to A, B to B, C to C, and D to D).

The default network address setting for the BMNET/BMNETEX is 1

When adding a BMNET, it must have a unique network address. The site configuration must be updated to include the panel added (see 6.2). If the site configuration is not updated, the panel will not be seen by the rest of the network and importantly any outstations connected to that panel will not operate as they will not be seen by the rest of the network.

5.5 Exchange PCB Dipswitch Settings

The Beacon network is formed from BMNET master stations, BMNETEX expander panels, and BM2/4/8 master stations. Each panel on the network has to have a unique network address. This address is set by the dipswitches on the Exchange PCB. The address is a binary number given by the positions of dip switches 1 to 6, with valid addresses lying between 1 and 64 inclusive.

Network address dipswitch setting						
Addr	1	2	3	4	5	6
1	1	0	0	0	0	0
2	0	1	0	0	0	0
3	1	1	0	0	0	0
4	0	0	1	0	0	0
5	1	0	1	0	0	0
6	0	1	1	0	0	0
7	1	1	1	0	0	0
8	0	0	0	1	0	0
9	1	0	0	1	0	0
10	0	1	0	1	0	0
11	1	1	0	1	0	0
12	0	0	1	1	0	0
13	1	0	1	1	0	0
14	0	1	1	1	0	0
15	1	1	1	1	0	0
16	0	0	0	0	1	0
17	1	0	0	0	1	0
18	0	1	0	0	1	0
19	1	1	0	0	1	0
20	0	0	1	0	1	0
21	1	0	1	0	1	0
22	0	1	1	0	1	0
23	1	1	1	0	1	0
24	0	0	0	1	1	0
25	1	0	0	1	1	0
26	0	1	0	1	1	0
27	1	1	0	1	1	0
28	0	0	1	1	1	0
29	1	0	1	1	1	0
30	0	1	1	1	1	0
31	1	1	1	1	1	0
32	0	0	0	0	0	1
33	1	0	0	0	0	1
34	0	1	0	0	0	1
35	1	1	0	0	0	1
36	0	0	1	0	0	1
37	1	0	1	0	0	1
38	0	1	1	0	0	1
39	1	1	1	0	0	1
40	0	0	0	1	0	1
41	1	0	0	1	0	1
42	0	1	0	1	0	1
43	1	1	0	1	0	1
44	0	0	1	1	0	1
45	1	0	1	1	0	1
46	0	1	1	1	0	1
47	1	1	1	1	0	1
48	0	0	0	0	1	1
49	1	0	0	0	1	1
50	0	1	0	0	1	1
51	1	1	0	0	1	1
52	0	0	1	0	1	1
53	1	0	1	0	1	1
54	0	1	1	0	1	1
55	1	1	1	0	1	1
56	0	0	0	1	1	1
57	1	0	0	1	1	1
58	0	1	0	1	1	1
59	1	1	0	1	1	1
60	0	0	1	1	1	1
61	1	0	1	1	1	1
62	0	1	1	1	1	1
63	1	1	1	1	1	1
64	0	0	0	0	0	0

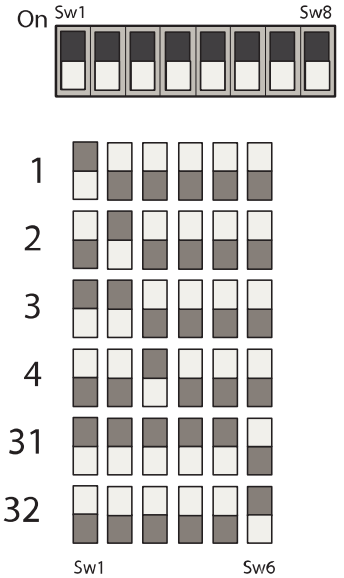

Note: Dipswitch 7 & 8 are Reserved for future expansion.

6 Configuration

6.1 Configuration file

All BMNET and BMNETEX panels on the network are configured from the configuration file (LXConfig.csv) located on the Micro SD card that is fitted as standard.

The configuration file contains information on general site details, the panels that are present, the lines used by each panel, and which line is controlled by which panel.

The configuration file is generated from the supplied spreadsheet. This spreadsheet is available in both Apache Open Office Calc format, and Microsoft Excel format. All details are entered into the appropriate spreadsheet.

This spreadsheet MUST then be saved as a CSV file for use by the BMNET.

In Excel use the save as option and set the [File name] to "LXConfig" and [Save as Type] to "CSV (Comma delimited)"

When the configuration is loaded from the Micro SD card, the BMNET looks for the file **LXConfig.csv**. It will not load the configuration from any other file.

6.2 Configuration Procedure

To update the configuration:

1. Remove the Micro SD card from the MMC card holder on the rear of the BMNET Display PCB
2. Use the supplied Micro SD card reader to open the Configuration spreadsheet contained on the Micro SD card. The configuration spreadsheet is available in both Apache Open Office Calc format and the Microsoft Excel format.
3. Update the Configuration spreadsheet as described below in sections 6.3 to 6.6.
4. Save the updated Configuration spreadsheet with a relevant filename. We suggest a copy is kept elsewhere as a backup.
5. **The spreadsheet MUST THEN BE SAVED AS LXConfig (Comma delimited) format onto the Micro SD card. The file type must be changed in the *Save as Type* drop-down list to CSV (comma delimited) in Excel, or Text CSV in OpenOffice Calc.** This is the file used by the BMNET to load the configuration.
6. The Micro SD card can then be removed from the card reader and then reinserted into the MMC card holder.
7. From the Home screen, log in at access level 3 as mentioned in section 7.5.3 and 7.6.
8. Press the  button. A confirmation screen is shown. Press **Yes** to start loading the configuration. First the file is checked to ensure it is valid. If valid, the configuration data is loaded into memory from the SD card. Then a copy of the configuration is stored in onboard memory storage. Then the configuration is sent around the network. All panels will be updated according the new configuration, so configuration can be done from the one panel.

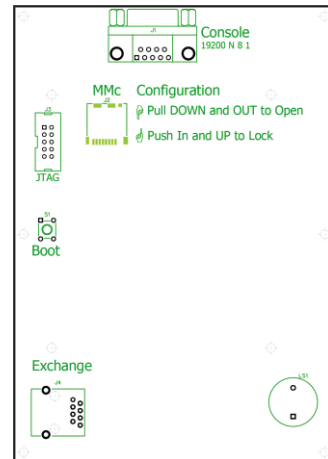

Note that the configuration stored on the Micro SD cards on other master stations are not updated with the new configuration. Either only use one for configuration (Preferred option), or store the updated configuration on all Micro SD cards to ensure discrepancies do not occur in future.

6.3 Configuration file sections

The configuration file is split into 3 discrete sections: Project details, Panel details, Line details, and file version (see below).

File version Project details

Project details							Panel 1 config			
Project							Name row 1			
Site name							Name row 2			
Installer							Type			
Contact							Net			
Version 1.1	Outstation text		Alarm text		Fault text		Day	Night	Fault	
Line	Used	Row 1	Row 2	Row 1	Row 2	Row 1	Row 2			
Panel 1										
1	EVCS	Ground Floor	North Stair	Line 1	Panel 1	Ground Floor EVCS	Main Entrance	Yes	Yes	Yes
2	EVCS	Floor 1	North Stair	Line 2	Panel 1	Floor 1 EVCS	Stairwell	Yes	Yes	Yes
3	EVCS	Floor 2	North Stair	Line 3	Panel 1	Floor 2 EVCS	Stairwell	Yes	Yes	Yes
4	EVCS	Floor 3	North Stair	Line 4	Panel 1	Floor 3 EVCS	Stairwell	Yes	Yes	Yes
5	Assist	Line 5	Panel 1	Ground Floor	Public WC	Ground Floor WC	Panel 1	Yes	Yes	Yes
6	Assist	Line 6	Panel 1	Floor 1	Bedroom 102	Floor 1 WC	Panel 1	Yes	Yes	Yes
7	Assist	Line 7	Panel 1	Floor 2	Bedroom 202	Floor 2 WC	Panel 1	Yes	Yes	Yes
8	Assist	Line 8	Panel 1	Floor 3	Bedroom 302	Floor 3 WC	Panel 1	Yes	Yes	Yes
Panel 2										
1	EVCS	Floor 4	North Stair	Line 1	Panel 2	Floor 4 EVCS	Expander 1 Rm400	Yes	Yes	Yes
2	EVCS	Floor 5	North Stair	Line 2	Panel 2	Floor 5 EVCS	Expander 1 Rm400	Yes	Yes	Yes
3	EVCS	Floor 6	North Stair	Line 3	Panel 2	Floor 6 EVCS	Expander 1 Rm400	Yes	Yes	Yes
4	Both	Floor 7	North Stair	Floor 7	Bedroom 732	Floor 7 EVCS/WC	Expander 1 Rm400	Yes	Yes	Yes
5	Assist	Line 5	Panel 2	Floor 4	Bedroom 402	Floor 4 WC	Expander 1 Rm400	Yes	Yes	Yes
6	Assist	Line 6	Panel 2	Floor 5	Bedroom 502	Floor 5 WC	Expander 1 Rm400	Yes	Yes	Yes
7	Assist	Line 7	Panel 2	Floor 6	Bedroom 602	Floor 6 WC	Expander 1 Rm400	Yes	Yes	Yes
8	Assist	Line 8	Panel 2	Floor 7	Bedroom 702	Floor 7 WC	Expander 1 Rm400	Yes	Yes	Yes

Line details

Panel details

6.4 Project details

This section contains the project details that are common to all panels for this project. These details are shown in the Info box available on the home screen. Additionally the site name is shown above the logo on the home screen.

Project	
Site name	
Installer	
Contact	

6.4.1 Project

This line is used to store the project name. The project name is limited to 30 characters. The project name is only available on the Info screen.

6.4.2 Site name

This line is used to store the site name. The site name is limited to 30 characters. The site name is shown on both the home screen and the Info box.

6.4.3 Installer

This line is used to store the name of the installer. The installer name is limited to 30 characters. The installer's name is shown in the Info box.

6.4.4 Contact

This line is used to store the contact details. The contact details are limited to 30 characters. The contact details are shown in the Info box.

6.4.5 Version details

This section shows the version number of this configuration file. This box cannot be altered.

6.5 Line details

This section contains the details that govern each line on the system. Each panel can have up to 8 lines. Each line can be configured to be used or not, and if it is used, then the text that is shown can be configured.

Version 1.0		Outstation text		Alarm text		Fault text	
Line	Used	Row 1	Row 2	Row 1	Row 2	Row 1	Row 2
Panel 1							
1	EVCS	Ground Floor	Panel 1	Line 1	Panel 1	Ground Floor EVCS	Main Entrance
2	EVCS	Floor 1	Panel 1	Line 2	Panel 1	Floor 1 EVCS	Stairwell
3	EVCS	Floor 2	Panel 1	Line 3	Panel 1	Floor 2 EVCS	Stairwell
4	EVCS	Floor 3	Panel 1	Line 4	Panel 1	Floor 3 EVCS	Stairwell
5	Assist	Line 5	Panel 1	Ground Floor	Panel 1	Ground Floor WC	Panel 1
6	Assist	Line 6	Panel 1	Floor 1	Panel 1	Floor 1 WC	Panel 1
7	Assist	Line 7	Panel 1	Floor 2	Panel 1	Floor 2 WC	Panel 1
8	Assist	Line 8	Panel 1	Floor 3	Panel 1	Floor 3 WC	Panel 1

6.5.1 Line

This is the index number of the line for this panel. The panel index is given by the panel bar. This index number cannot be altered.

6.5.2 Used

This determines if this line is used or not. If it is used, the type of device on this line is specified. There are 5 options available via a drop-down list:

None: no device present on this line.

EVCS: an outstation present on this line, the outstation can be a Type A (including Jack Points), Type B, or Type C.

Assist: an "Assist Call" emergency assistance alarm system present on this line.

Both: an outstation and an "Assist Call" present on this line.

Switch: a switch input present on this line.

Line	Used
1	EVCS
2	EVCS
3	EVCS
4	EVCS
5	Assist
6	Assist

6.5.3 Outstation text

The outstation text is used to identify an outstation that is calling, in a conversation, or on hold. The Call screen displays all active outstations, using the outstation text to identify the outstations.

The Outstation text is split into 2 rows, with each row having a maximum of 20 characters. Row 1 is the top row, and Row 2 is the bottom row.

Version 1.1		Outstation text	
Line	Used	Row 1	Row 2
1	EVCS	Ground Floor	North Stair
2	EVCS	Floor 1	North Stair
3	EVCS	Floor 2	North Stair
4	EVCS	Floor 3	North Stair

6.5.4 Alarm text

The Alarm text is used to identify an active, or acknowledged, "Assist Call" alarm. The Alarms screen displays all active "Assist Call" alarms, using the alarm text to identify the alarms.

The Alarm text is split into 2 rows, with each row having a maximum of 20 characters. Row 1 is the top row, and Row 2 is the bottom row.

Version 1.1		Alarm text	
Line	Used	Row 1	Row 2
Panel 1			
5	Assist	Ground Floor	Public WC
6	Assist	Floor 1	Bedroom 102
7	Assist	Floor 2	Bedroom 202
8	Assist	Floor 3	Bedroom 302

6.5.5 Faults text

The Fault text is used to identify any fault associated with that line. This text allows additional information i.e. where equipment is fed from or located in addition to line identity. The Faults screen displays all faults, including line faults, where the line faults use the fault text to identify the line in fault.

The Fault text is split into 2 rows, with each row having a maximum of 20 characters. Row 1 is the top row, and Row 2 is the bottom row.

Version 1.1		Fault text	
Line	Used	Row 1	Row 2
1	EVCS	Ground Floor EVCS	Main Entrance
2	EVCS	Floor 1 EVCS	Stairwell
3	EVCS	Floor 2 EVCS	Stairwell
4	EVCS	Floor 3 EVCS	Stairwell

6.6 Panel details

This section contains the details that govern each panel on the system. There can be a total of up to 64 panels.

The panel details contain:

- Panel name.
- Panel type.
- Network monitoring
- Day setting for line.
- Night setting for line.
- Fault setting for line

Panel 1 config			
Name row 1	Security		
Name row 2	Admin Suite		
Type	TMS		
Net	Both		
Day	Night	Fault	
Panel 1			
Yes	Yes	Yes	
Yes	Yes	Yes	
Yes	Yes	Yes	
Yes	Yes	Yes	
Yes	Yes	Yes	
Yes	Yes	Yes	
Yes	Yes	Yes	
Yes	Yes	Yes	

6.6.1 Panel name

The panel name is the text that appears on the Home screen, and is used to identify the panel when a panel fault has occurred.

The panel name is split into 2 rows, with each row having a maximum 20 characters. Row 1 is the top row, and Row 2 is the bottom row.

6.6.2 Panel type

The network can consist of different types of panel. The panel type is chosen from the drop-down list. The options are:

Option	Description
None	No panel
TMS	BMNET Touchscreen Master Station
EX8	BMNEXTEX System Expander Panel
LX228	BM2/4/8 Master Station

6.6.3 Network settings

The network settings are a drop-down list that sets which network ports to monitor for this panel. The network options are:

Option	Description
Both	net in and net out ports monitored
In	net in port monitored only
Out	net out port monitored only
None	neither network port monitored

6.6.4 Day setting

The day setting determines if this outstation or Assist Call alarm is shown on the screen when activated during daytime. If day setting is No, then this outstation/Assist Call alarm will not be shown on the specified panel. The day setting is set for all defined lines on all panels. To set daytime, see 7.8.1.

The day setting options are:

Option	Description
Yes	Outstation/"Assist Call" alarm is shown on touchscreen display when activated.
EVCS	Only outstation is shown on touchscreen display when activated.
Assist	Only "Assist Call" alarm is shown on touchscreen display when activated.
No	Outstation/"Assist Call" alarm is not shown on touchscreen display.

6.6.5 Night setting

The night setting determines if this outstation or "Assist Call" alarm is shown when activated during night time. To set night-time, see 7.8.1. The night setting options are the same as the day setting options.

6.6.6 Fault setting

The fault setting determines if line faults for the specified line are shown on this panel. This setting only disables the line faults being shown on this screen. It does not disable fault monitoring, thus line faults will still be shown on other screens.

Option	Description
Yes	Outstation/"Assist Call" faults are displayed on touchscreen display.
No	Outstation/"Assist Call" faults are not displayed on touchscreen display.

6.7 Custom logo

A custom logo can be shown on the home screen instead of the default logo. To use a custom logo, a bitmap file must be saved to the root directory of the Micro SD card with the following properties:

- Name: logo must be saved as **Logo.BMP**.
- Format: 16bit bitmap (BMP) or 24bit bitmap (BMP).
- Size: 200x200 pixels.

7 Operation

All operations are under the command of the BMNET Master Station using the touchscreen display.

7.1 Touchscreen display operation

All buttons on the touchscreen display are activated by pressing the button. Buttons are defined as an icon surrounded by either a square or hexagonal border.

All lists on the display can be scrolled. Scrolling is accomplished by pressing the touchscreen in the scroll area, and keeping the finger pressed, moving the finger either up or down the screen to scroll either up or down. The highlighted area is defined as the section of the screen where the text is located, next to the text icon. The icons are not part of the scrollable area, thus scroll actions cannot be performed when pressing the icons. Instead, the icons are buttons, and any action applicable to that icon will be performed instead.

7.2 Navigation button operation

The navigation buttons located under the touchscreen display can be used in most circumstances to duplicate using the touchscreen display.

Left button	Scroll up through the list on screen when appropriate
Middle button	Select the central highlighted item on screen when appropriate
Right button	Scroll down through the list on screen when appropriate.

7.3 Header bar

The header bar is present at the top of all screens. This bar allows the user to switch to the desired screen. It also displays the number of active events. This number of calls, alarms, and faults is available on all screens.



	Pressing the Calls button will show the Calls screen. The numbers of calls are displayed within this button.
	Pressing the Alarms button will show the Alarms screen. The numbers of alarms are displayed within this button.
	Pressing the Faults button will show the Faults screen. The numbers of faults are displayed within this button.
	Pressing the Home button will show the Home screen.

7.4 Footer bar

The footer bar shows the time of day, the current access level, the time and the date.



The time of day is shown as an icon:

	Panel in day time mode.
	Panel in night time mode.
	Panel Disabled

The access level is shown as an icon:



	Access level 1
	Access level 2
	Access level 3

7.5 Home screen

The Home screen is the default screen that is shown when there are no active calls or alarms. There are controls that allow the user access to panel information. The controls shown depend up on the access level. This access level is shown by icon in the footer bar.

7.5.1 Home screen access level 1

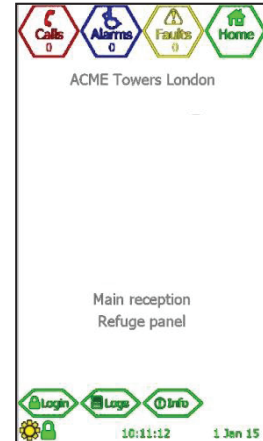

The following buttons are available at access level 1:

	Shows PIN entry screen.
	Shows log screen.
	Shows information screen.



7.5.2 Home screen access level 2





All access level 1 buttons are available, along with the following buttons:

	Performs panel indicator test
	Shows set time and date screen.

The Login button is replaced with a Logout button.



7.5.3 Home screen access level 3

All access level 1 and access level 2 buttons are available, along with the following buttons:

	Shows change PIN screen.
	Loads configuration from SD card. Load progress is shown on screen.
	Shows panel and line configuration edit screen.
	Saves configuration to SD card. Save progress is shown on screen.

7.6 PIN entry screen

This screen shows a number pad that enables the user to enter a 4 digit PIN, plus the following buttons:

	Clear all digits.
	Delete last digit.

When the 4th digit is entered, if the PIN is valid, it will log in at the appropriate access level, and displays the menu options for the desired access level (see above for options available).

- Access level 2: PIN = 1664
- Access level 3: PIN = 1812

If the PIN is invalid, the home screen is shown with an error message.

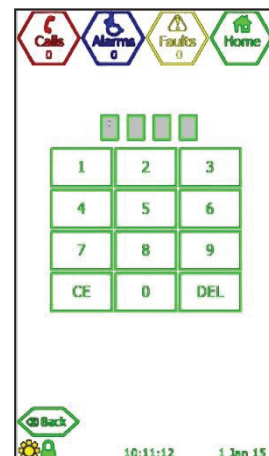

7.7 Info screen

The info screen displays additional information. The additional information is:

- Project name – Name given to the project.
- Site name – Name given to the site. This is displayed on the home screen, and is common to all panels on site.
- Panel name – Name given to this specific panel.
- Network address – Address for this specific panel.
- Installer – Name of installer.
- Contact – Contact details.
- Version – Version number and build number.

Project
ACME Towers
Site name
ACME Towers London
Panel name
Main reception
Refuge panel
Network Address: 1
Installer
Joe Bloggs
Contact
Wile E Coyote 0845 123 4567
Version: 1.0 Build 1

7.8 Clock screen

The clock screen shows boxes that allow the user to set the Clock time and date, the Day time, and the Night time. The Daylight Saving checkbox enables or disables daylight savings time.

The time and date are sent via the network so all panels will be updated. This ensures all panels are on the same time, and have the same Day start time and Night start time.

To select a box, either press the desired box to select that box or use the navigation buttons on the keypad.

H M D M Y
 Clock 0 0 1 1 15
 Day 0 0 Daylight saving
 Night 0 0
 1 2 3
 4 5 6
 7 8 9
 <-- 0 -->
 Back Save

	Moves highlighted box back one place.
	Moves highlighted box forward one place.
	Saves time, date, day start, and night start. Sends this data to all panels on the network, and updates all panels with this data. Shows home screen.
	Exits this screen and shows home screen without updating time and date.

7.8.1 Day and night modes

All panels on the network have the same day and night time. Updating the day/night time will update the time on all panels. Each panel has its own configuration for which lines are shown during the day or night.

When the time reaches the Day time, the panel enters Day mode. Only lines configured to operate during the day will be shown on the touchscreen display.

When the time reaches the Night time, the panel enters Night mode. Only lines configured to operate during the night will be shown on the touchscreen display.

If both Day time and Night time are set to 00:00, then the panel will be considered to be continually in Day mode.

7.9 Change PIN

Pressing the button will show the change PIN screen. This screen allows the user to change the PIN for both level 2 access and level 3 access.

To select a box, press that box on screen. This box is then highlighted, and any number entered is cleared.

To enter a number, press the corresponding number on the number pad.

CE on the number pad clears the current box.

DEL on the number pad deletes the last number entered.

Access level 2 - User
 PIN Repeat
 Access level 3 - Engineer
 PIN Repeat
 1 2 3
 4 5 6
 7 8 9
 CE 0 DEL

7.9.1 Change Access Level 2 PIN

The level 2 access PIN can be changed by pressing the level 2 PIN box to highlight it, then entering the

new PIN into the PIN box. Re-enter the PIN in the level 2 Repeat box. If both the PIN and the Repeat numbers are the same, the Save button is shown. Press the Save button to change the level 2 PIN to the new number.

If the level 2 PIN and the level 2 Repeat boxes change colour to yellow, then the two numbers are different, and the Save button is hidden.

If the level 2 PIN box and the level 3 PIN box change colour to yellow, then the PIN entered for level 2 is the same as the level 3 PIN, and the Save button is hidden, as these 2 PINs can never be the same.

7.9.2 Change Access Level 3 PIN

The level 3 access PIN can be changed by pressing the level 3 PIN box to highlight it, then entering the new PIN into the PIN box. Re-enter the PIN in the level 3 Repeat box. If both the PIN and the Repeat numbers are the same, the Save button is shown. Press the Save button to change the level 3 PIN to the new number.

If the level 3 PIN and the level 3 Repeat boxes change colour to yellow, then the two numbers are different, and the Save button is hidden.

If the level 2 PIN box and the level 3 PIN box change colour to yellow, then the PIN entered for level 2 is the same as the level 3 PIN, and the Save button is hidden, as these 2 PINs can never be the same.

7.10 Load configuration

To load the configuration stored on the Micro SD card, press the  button. A confirmation screen is shown, and when **Yes** is pressed, the configuration is first loaded from the configuration file, and then transmitted via the network to all panels, so all panels will be updated with this configuration.

Whilst loading the configuration, normal operation of the TMS is suspended.

If there is a problem loading from the configuration file, **Load failed** is displayed.

7.11 Save configuration

To save the configuration to file on the Micro SD, press the  button. A confirmation screen is shown, and when **Yes** is pressed, the configuration file is overwritten.

Whilst saving, normal operation of the TMS is suspended.

7.12 Edit configuration

The configuration for all panels and all lines can be edited via this screen. The site name, panel name, panel type, network monitoring, and line details can

be edited by pressing the  button next to the relevant option.

To exit the configuration screen, press the  button.

7.12.1 Project settings

Press the  button to show the project settings screen that allows the editing of the project name, site name, installer name, and contact details.

7.12.1.1 Project name

The project name is common to all panels on the network. To change the project name, press the  button next to the project name. This will display the keyboard that allows the user to change the project name.

7.12.1.2 Site name

The site name is common to all panels on the network. To change the site name, press the  button next to the site name. This will display the keyboard that allows the user to change the site name.

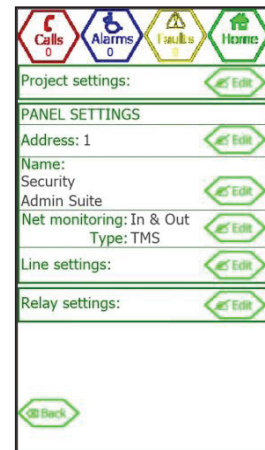

7.12.1.3 Installer name

The installer name is common to all panels on the network. To change the installer name, press the  button next to the installer name. This will display the keyboard that allows the user to change the installer name.

7.12.1.4 Contact details

The contact details are common to all panels on the network. To change the contact details, press the  button next to the contact details. This will display the keyboard that allows the user to change the contact details.

7.12.2 Panel details

The panel details show the configuration for the panel at the given address. The panel address and name is shown.

To alter the panel type, press the appropriate button: None, TMS, EX8, or LX228 (see 7.12.5).

To enable network monitoring, select the network port to be monitored. When wired in a ring, both network ports must be monitored (see 7.12.5).

EVCS calls and "Assist Call" alarms can be enabled or disabled on this panel via a switch input. This allows operations to be switched from one panel to another panel if the situation requires it.

Lock setting determines what is affected when the switch input is ACTIVE (see 7.12.6).

Lock action determines if the EVCS calls and/or "Assist Call" alarms are either enabled or disabled when the switch input is ACTIVE.

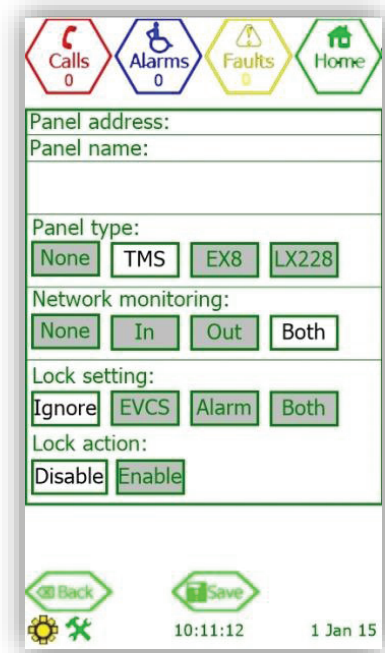

7.12.3 Address

The network address for the selected panel is displayed. To view a different panel, press the  button to display the panel select screen.

On the panel select screen, scroll to the panel desired, then press the button next to the panel name to select that panel. The configuration screen is then shown with details of the panel selected displayed.

Use the page navigation buttons to move list to first panel, move list down one page, move list up one page, and move list to last panel.

The text colour for each panel defines the panel status as follows:

- **Light Green:** Panel is present and configured.
- **Yellow:** Panel is not present but is configured.
- **Purple:** Panel is present but is not configured.
- **Dark Green:** Panel is not present or configured.

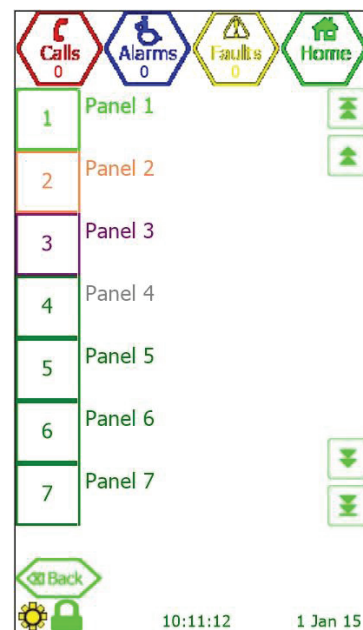





The text for the central entry will be white to show this entry will be selected if the Accept navigation button is pressed, but the icon for this entry will be in the appropriate colour to show its status.

7.12.4 Name

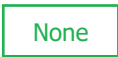

The panel name for the selected panel is displayed. Press the  button to display the keyboard to edit the panel name.

7.12.5 Net monitoring and Type

The panel type is chosen by pressing the desired button:

	No panel at this address
	TMS at this address
	EX8 at this address
	LX228 at this address

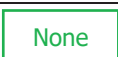
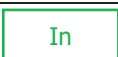
Network monitoring sets the monitoring option for the network in and network out ports. These are:

	Neither network port monitored
	Network in port monitored only
	Network out port monitored only
	Both network in and network out ports monitored





Press the  button to save any changes to the configuration, and to return to the configuration screen.

Press the  button to return to the configuration screen, discarding any changes.

If network monitoring is set to None, then no network faults are reported. Additionally no panel faults from remote panels are reported either. Only local panel faults will be shown. Line fault monitoring is configured for each line individually, and is independent to the network monitoring setting.

7.12.6 Lock Settings

This allows the panel to be enabled or disabled depending on the state of an input. This is used in connection with the line settings in 7.13.1 where a lock input is defined

	The panel as always enabled
	Network in port monitored only
	Network out port monitored only
	Both EVCS and Assist call alarms are enabled or disabled

7.12.7 Lock Action

This Setting set whether the panel is Disabled or Enabled when the switch input is ACTIVE.

7.13 Line details

This displays the current line details.

The panel network address and panel name is displayed for information purposes only.

The line buttons 1 to 8 are used to select the line desired. The current line button is highlighted. To change the line, press the desired line button.



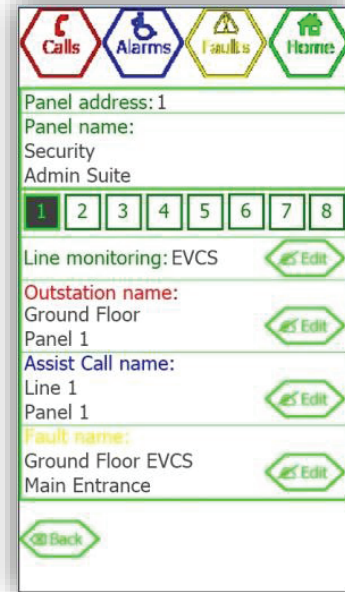

To edit these press the  button to show the line Monitoring screen.

Press the  button to return to the panel configuration screen.

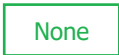

7.13.1 Line monitoring

Line monitoring displays the device connected to this line. The devices available are:

	No device attached
	Type A, Type B, or Type C outstation attached
	"Assist Call" emergency assistance alarm attached
	An EVCS outstation and an "Assist Call" attached
	A switch input is attached to this line

To change the line monitoring, or to set the line type options, press the  button to show the line monitoring screen.

The panel address and line index are displayed.

The selected line type button is highlighted. To change the line type, press the desired line type button.





7.13.1.1 Line Display Options (Day/Night)

Each line can be configured to show or ignore any active outstation, "Assist Call" alarm, or line fault for the local BMNET only. This means that each BMNET can be configured to show a different combination of calls, alarms, and faults. This is commonly used if a specific BMNET is required only to show specific items, e.g. only calls from Building A, but none from Buildings B and C, or "Assist Call" alarms only.

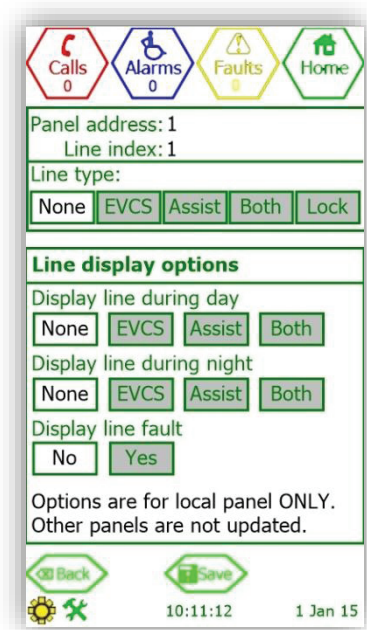
Note: all panels and all lines must be monitored from at least one panel at all times.

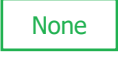
If a line is enabled, an incoming call is shown or an "Assist Call" alarm is shown for the local BMNET only. Each BMNET has to be configured separately for line enable. The line enable options for day and night are:



	No EVCS calls or "Assist Call" alarms are shown
	Only EVCS calls are shown
	Only "Assist Call" alarms for this line are shown
	Both EVCS calls and "Assist Call" alarms are shown

7.13.1.2 Display Line Faults

This enables fault display for the line on this panel only.

7.13.2 Outstation name

The outstation name is displayed. Press the  button to display the keyboard to edit the outstation name.

7.13.3 Alarm name

The "Assist Call" name is displayed. Press the  button to display the keyboard to edit the "Assist Call" name.

7.13.4 Fault name

The fault text for this line is displayed. Press the  button to display the call to edit the line fault text.

7.14 Relay settings

Press the  button to show the relay settings screen.

The relay settings screen refers to the operation of the in-use relay for the local panel only. The relay settings cannot be set for any remote panel via this screen. The in-use relay is located on the exchange PCB.

7.14.1 Relay settings screen

The relay settings screen is used to configure the operation of the in-use relay. The relay can be configured to close on any activation of an outstation or "Assist Call" alarm, or to only close when the local master handset is connected to an outstation. Note: a remote master handset is considered as an outstation.

7.14.2 Relay operation

The in-use relay has 3 different configurations:

In use	Any activation of outstation and/or Assist Call alarm depending upon setting.
Talk only	Local master handset in conversation with an outstation.
Disabled	Relay disabled.

To select the desired operation, press either the **In Use**, **Talk Only**, or **Disabled** button.

7.14.2.1 In use relay

The type of device that closes the in-use relay can be configured.

EVCS	At least one outstation activated.
Assist	At least one "Assist Call" alarm activated.
Both	Either an outstation or an "Assist Call" activated.

To select the desired device, press the **EVCS**, **Assist**, or **Both** button.

The in-use relay closes whenever the appropriate device activates, or after a programmable delay.

If the relay is programmed with a delay, the operation of the in-use relay changes. The in-use relay closes if the outstation has not been answered, or the "Assist Call" alarm has not been acknowledged within that set time period. A common use for this is for a remote signal to be activated signifying there is an active call/alarm that has not been answered.

Any delay can be entered, as long as the delay is under 10 minutes.

To alter the number of minutes, press the Min button, then enter the number of minutes using the number pad.

To alter the number of seconds, press the Sec button, then enter the number of seconds using the number pad.

Press the Reset button to reset the settings to In-use, Both with no delay, i.e. 0 minutes 0 seconds.

7.15 Keyboard

The keyboard is used to edit the displayed text.





The text to be edited is either 1 or 2 boxes containing the text. The current text is highlighted in white. This text is the one that will be edited.

Press the  button to save the text, and then return to the previous screen.

Press the  button to return to the previous screen, discarding any changed.

Press any character to append the highlighted text with that character. Once the maximum number of characters has been entered, no other characters can be added.

The control buttons available are:

	Clears highlighted text
	Deletes last character
	Switches to upper case.
	Switches to lower case.

7.16 Log screen

When an event occurs, that event is added to the log file. Each day has a different log file. Each log file can contain up to 65,535 events. All log files are stored on the attached Micro SD card. The log files are stored in CSV format, so they can be imported from the Micro SD card into a spreadsheet for analysis.

There are 3 different categories of events:

Calls: all outstation events, master handset events, and alarm events.

Faults: all fault occurred and fault cleared events.

Events: all operating system events.

The different categories are colour coded for easy identification.

7.16.1 Log header

The log header contains details for the current log file shown.



Date	Date of log shown
Entry	Range for entries shown
No. of entries	Total number of entries

7.16.2 Log entries

This section shows details for up to 8 events. Each entry has:

Icon detailing type of event.

Time event occurred.

If fault event, shows if fault occurred or cleared.

Event text.

7.16.3 Log navigation

If there are more than 8 entries in the log, then not all entries will be shown. The log can be navigated using the following options:

Scroll the screen by:

Touching the text of any entry, then move finger up or down

Pressing one of the navigation buttons shown on screen

Pressing the left or right navigation buttons on the panel below the screen

The navigation buttons shown on screen are:

	Move to first page.
	Move to next page.
	Move to previous page.
	Move to last page.
	Show calendar screen

7.16.4 Log filters











There are 3 different categories of entries: **Calls**, **Faults**, and **Events**. By pressing the relevant button, the entries for that category can be shown or hidden.

7.16.5 Log entries

Each log entry is specified by an icon, a description of the entry, the time of the entry, and if the entry refers to a fault, additional information on whether the fault has occurred or cleared.













7.16.6 Log entry icons for Call events

The following is a list of icons associated with call events:

	Incoming Type A outstation call.
	Incoming Type B outstation call.
	Conversation with Type A outstation.
	Conversation with Type B outstation.
	Type A outstation on hold.
	Type B outstation on hold.
	Master handset off hook.
	Master handset, Type A outstation, or Type B outstation on hook.
	"Assist call" alarm activated.
	"Assist call" alarm acknowledged.
	"Assist call" alarm cancelled.



7.16.7 Log entry icons for Fault events

The following is a list of icons associated with fault events:

	Line open circuit.
	Line short circuit.
	Line earth fault.
	Line card missing associated with this line.
	Master handset open circuit.
	Master handset short circuit.
	Network audio open circuit.
	Network audio short circuit.
	Network data fault.
	Mains failure.
	Battery open circuit.
	Battery short circuit.
	Battery impedance fault.
	CPU fault.
	Faults accepted.

7.16.8 Log entry icons for System events

The following is a list of icons associated with system events:

	New log file created.
	System powered and initialised.
	Watchdog reset

	Time and date changed.
	Configuration loaded from SD card
	Configuration saved to SD card
	Site name changed
	Panel name changed
	Panel type and network monitoring changed
	Line monitoring, day enable, night enable, and fault enable changed
	Outstation name changed
	Assist Call alarm name changed
	Fault text for line changed
	Access level 2 log in
	Access level 2 log out
	Access level 3 log in
	Access level 3 log out

7.16.9 Calendar to select previous log file

The log for each day is stored as a Comma Separated Variable (CSV) file on the attached Micro SD card. The log for a specific day can be recalled by pressing the calendar button on the log screen, and selecting the desired day on the calendar.

The calendar shows all days for the month displayed. The month can be changed by using the < and > buttons. If there is a log for a specific day, that day will be highlighted. If the day is not highlighted, then there will have been no log entries generated on that day, thus no file will have been created for that day.

Press a highlighted day to show the log for that day.

Note: by leaving the log screen to view either the Home, Faults, Calls, or Alarms, when the log screen is shown again, the log for the current day will be shown, and not the historic log.

To return to the log screen without choosing a day, press the Back button.

7.17 Call screen

The call screen is used to control the calls and conversations from outstations.









The outstations can be Fire Telephones (Type A) or a Disabled Refuge Points (Type B).

Type A outstation can be combined with a Type B to form a Type C outstation.

However, the indication of the call depends whether it was the Type A or the Type B that is in use.

When an outstation is in use, an icon appears that shows the state of that outstation.

The text associated with outstation is shown next to the icon. The outstation status icons are:

	Incoming Type A outstation call.
	Incoming Type B outstation call.
	Conversation with Type A outstation.
	Conversation with Type B outstation.
	Type A outstation on hold.
	Type B outstation on hold.
	Type A connected to remote panel.
	Type B connected to remote panel.

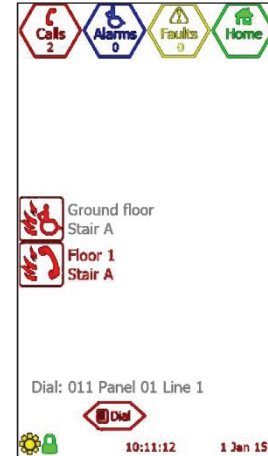

The extension number, panel address and line number of the central highlighted call is displayed below the call list.

7.17.1 Call screen operation

An entry can be selected by pressing the icon next to the name. Pressing the middle navigation button selects the central highlighted entry.

Scroll through the directory by either scrolling the screen or using the page navigation buttons until the desired outstation is displayed on screen (or is the central entry if using the middle navigation button).

Scrolling is accomplished by touching the outstation text, and moving the finger up or down as appropriate.



The left and right navigation buttons beneath the screen can also be used to scroll the directory.

7.17.2 Accepting incoming call

An incoming Type A outstation call has the  icon. An incoming Type B outstation has the  character.

To accept the incoming call:



1. Lift the master handset off its cradle.
2. Scroll through the list until the desired call is on screen (or is the central call, in white, if using the middle navigation button to control the call).
3. Press the icon for the selected call, or press the middle navigation button below the screen to select the central call.

The icon will change to  for a Type A outstation, or  for a Type B outstation. This indicates that a conversation is now possible with the selected outstation.

7.17.3 Place call on hold

If a conversation is to be put on hold:

1. Scroll through the list until the desired call is on screen (or is the central call, in white, if using the middle navigation button to control the call).
2. Press the icon for the selected call, or press the middle navigation button below the screen to select the central call.

The icon will change to  for a Type A outstation, or  for a Type B outstation. This indicates that this conversation has now been placed on hold. If there was also another ongoing conversation as part of a conference call, this other conversation will still be active.



7.17.4 Disconnect all calls

Placing the master handset back onto its cradle will disconnect all calls. All conversations will end, and the affected outstations will revert to incoming call. Any outstations on hold will be taken off hold, and will revert to incoming call.

To stop the incoming call, the outstation must be cancelled at source, i.e. the person at the outstation must cancel the call, either by placing the Type A outstation back onto its cradle, or by pressing the call/cancel button on the Type B outstation.

7.17.5 Call screen buttons

The buttons associated with the call screen are:

	Shows directory screen which allows user to choose from the list of allowed extensions.
	Shows dial screen which allows user to dial a line by entering extension number.

7.18 Directory screen

To place a call to an outstation, the master handset has to be off hook. Thus, if the master handset is on the cradle, a screen appears informing the user to pick up the master handset.

The directory screen shows the list of all outstations available to this TMS, with 7 outstations displayed on screen at any one time. The icon next to each outstation shows the state of that outstation.

Master handsets for remote panels are also shown on this screen. The master handset name displayed is the name for this panel. The remote master handset is considered the same as an outstation in regards to operating it.

The text below the directory list shows the extension number for the selected outstation, along with the panel and line index.

The outstations are shown in alphabetical order.



7.18.1 Directory screen operation

An entry can be selected by pressing the icon next to the name. Pressing the middle navigation button selects the central highlighted entry.

Scroll through the directory by either scrolling the screen or using the page navigation buttons until the desired outstation is displayed on screen (or is the central entry if using the middle navigation button).

Scrolling is accomplished by touching the outstation text, and moving the finger up or down as appropriate.

The left and right navigation buttons beneath the screen can also be used to scroll the list.

The  button moves to first directory entry.

The  button moves the directory up one page.

The  button moves the directory down one page.

The  button moves to the last directory entry.

7.18.2 Placing an outgoing call to an outstation



To place an outgoing call to an outstation:

1. Lift the master handset off the cradle.
2. Press the icon on screen for the desired outstation, or press the middle navigation button below the screen to select the central entry.

The BMNET will switch to the call screen, and the outstation text will appear with the icon  to indicate the master is calling the outstation. When the outstation answers, the conversation will commence immediately.

7.18.3 Directory screen buttons

The buttons associated with the directory screen are:

	Shows the call screen.
	Shows dial screen which allows user to dial a line by entering extension number.



7.19 Dial screen

To place a call to an outstation, the master handset has to be off hook. Thus, if the master handset is on the cradle, a screen appears informing the user to pick up the master handset.

The dial screen is used to call any outstation by entering the extension number for that outstation. The extension number is a 3 digit number. The first 2 digits are the panel network address, and the third digit is the line number for that outstation (always between 1 and 8)

When the extension number is entered, the name for that line is displayed. If the line is valid, the dial button appears. If the line is not defined, a warning message is displayed.

To call that outstation, press the  button.

	Shows the call screen.
	Shows directory screen which allows user to choose from the list of allowed extensions.

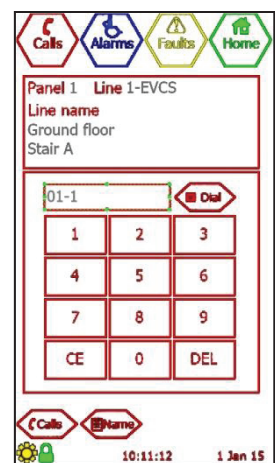



7.20 Alarms screen

Any active or acknowledged "Assist Call" alarm is shown on the Alarms screen.

If there is one alarm, it is shown in the centre of the screen, with the alarm text in white, and the icon showing the status of the alarm. This alarm is the selected alarm.

If there is more than one alarm, the other alarms are shown either above or below the selected alarm, with the alarm text in blue.

The "Assist Call" alarm states are:

	Active "Assist Call" alarm
	Acknowledged "Assist Call" alarm

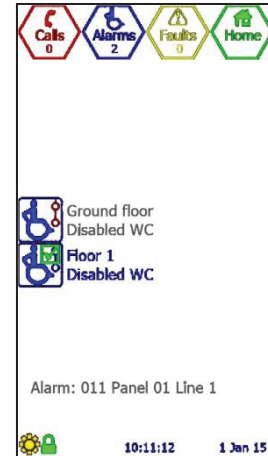

The panel address and line number for the central highlighted alarm is displayed below the alarm list.

7.20.1 Alarm screen operation

An alarm can be selected by pressing the icon next to the name. Pressing the middle navigation button selects the central highlighted alarm.

Scroll through the directory by either scrolling the screen or using the page navigation buttons until the desired alarm is displayed on screen (or is the central alarm if using the middle navigation button).

Scrolling is accomplished by touching the alarm text, and moving the finger up or down as appropriate.

The left and right navigation buttons beneath the screen can also be used to scroll the list.

7.20.2 Acknowledge "Assist Call" alarm

To acknowledge an alarm:

1. Scroll through the alarms until the desired alarm is on screen (or is the central alarm if using the middle navigation button).
2. Press the alarm icon on screen, or press the middle navigation button below the screen.

This will acknowledge that alarm, and the icon will change to represent this.

7.21 Fault screen

The fault screen shows all faults that are current on every panel on the network.

If there is one current fault, is shown in the centre of the screen, with the fault text in white, and the icon showing the type of fault. The fault text is either the panel name, if it is a panel fault, or the customisable fault text for the appropriate line if it is a line fault. The icon depicts the type of fault, and the fault status line at the bottom of the screen describes the type of fault for the central highlighted fault only.

If there is more than one current fault, these faults are shown above and below the selected fault, with the fault text in yellow.

The accept button  is shown if there are unaccepted faults.

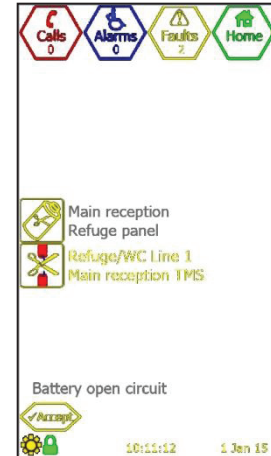

7.21.1 Fault screen operation

If there is more than one fault, the faults can be scrolled by touching the screen where the fault text is, and moving the finger up or down as appropriate.

The left and right navigation buttons located beneath the screen can also be used to scroll the fault list.

7.21.2 Accepting faults

If the current faults are unaccepted, the accept button  is shown. Additionally, the fault buzzer will be sounding, and the general fault status LED below the screen will be flashing.

To accept the faults, press the  button.

When faults are accepted, the  button will disappear, the fault buzzer will cease, and the general fault status LED will stop flashing, and be illuminated.

If a new fault occurs, the panel will revert back to the unaccepted state, the fault buzzer will resound, and the general fault status LED will start flashing. The  button will be shown again.

If a fault has been accepted, but not cleared within 8 hours of accepting the fault, the panel will revert back to the unaccepted fault state again. This will re-sound the fault buzzer, flash the general fault status LED, and the  button will be shown.

7.21.1 Fault information

Press the fault icon to view additional information about the fault. The information provided is:

Fault	Type of fault
Time	Time and date when fault occurred
Panel name	Name of panel where fault occurred
Network address	Network address of panel where fault occurred
Panel type	Type of panel where fault occurred – TMS, EX8, LX228, or None
Line number	Index of line in fault. This is only shown if the fault is a line fault or a master handset fault
Line type	Type of line in fault. This is only shown if the fault is a line fault or a master handset fault
Line description	Fault description of line in fault. This is only shown if the fault is a line fault

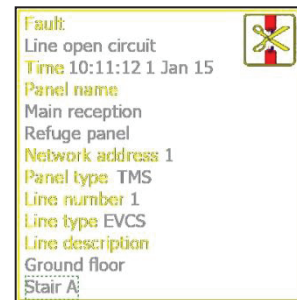











7.21.2 Fault types

The faults can be split into 2 general categories: panel faults and line faults.





7.21.3 Panel faults

Panel faults are faults that occur on the panel itself. These are:

	Mains power fault
	Battery missing or open circuit
	Battery short circuit
	Battery impedance fault
	Master handset missing or open circuit
	Master handset short circuit
	CPU failed or watchdogged
	Network audio open circuit on indicated port
	Network audio short circuit on indicated port
	Network data fault
	Panel missing

7.21.4 Line faults

Line faults are faults that occur on a line attached to the panel. These are:

	Line open circuit or end-of-line missing
	Line short circuit
	Line earth fault
	Line card missing

8 Indications and Controls



8.1 Mode Indicator Summary

Mode	Description
Green solid	Normal state
Red solid	Outstation off hook
Blue solid	"Assist Call" active
Yellow Solid	Refuge (type B) points disabled
Flashing Red/Blue	Incoming call/ Assist Call alarm at same time

8.2 Power supply and CPU indicator Summary

AC	DC	PSU	CPU	Description
✓				Mains OK
x		✓		Mains failure
✓	✓			Battery OK
✓	x	Flash		Battery open circuit
✓	x	✓		Battery short circuit
✓	Flash	✓		Battery high impedance
✓		✓	✓	PSU processor fail
✓			✓	Display or Exchange Processor Fault or Display-Exchange comms flt

✓ = LED illuminated

x = LED off

Flash= LED Flashing

9 Commissioning procedure

The commissioning should be carried out by a competent person who has a basic knowledge and understanding of the design and installation sections of BS5839 part 9:2021, and has access to the specification of the project.

The 500v insulation tests should have been carried out by the installer and the results made available to the commissioning engineer.

All cables should be correctly labelled.

Test field wiring and check for end-of-line 10KΩ resistor. Check cables are clear from any short or open circuits.

Connect outstation cables into Line Cards ensuring the Earth is sleeved and terminated into the Earth block.

Configure relevant dipswitches for the network settings that may be required as per the set up section in this manual.

Connect the network cabling (if appropriate), ensuring Net OUT ABCD is correctly connected to Net IN ABCD and the ring is continuous. Only Connect the Earth screen of the Net IN cables

Power up the BMNET Master Station using mains only, fed from a 3A fuse fitted in an unswitched fused spur. The AC power indicator will be illuminated, and the DC power indicator is extinguished. The PSU fault and General fault indicators will be illuminated. There should be no line fault indicators illuminated.

If there are no line faults present, the battery may be connected. The DC power indicator will be illuminated, and the PSU fault and General fault indicators are extinguished when battery is connected.

If there are any line fault indicators illuminated, then the field wiring should be checked prior to the battery being connected.

Repeat the power up section for any additional BMNETEX Expander panels or additional BMNET panels.

Upload the site configuration from the Micro SD card (recommended) or using the menus.

If device missing or network faults are reported address these before continuing. Once remedied re-upload the site configuration to ensure all panels are programmed

Lift the master handset receiver and listen for a cadence tone.

All outstations may be tested now, visit each outstation in turn and test that it is connected to the correct Master Station or Expander panel and perform an intelligibility test. This test should be conducted when the building has normal background noise levels. The intelligibility test requires two personnel.

Where Assist Call is fitted, all pull cords in each circuit should be tested, acknowledged at the panel, cancelled at the call location and the panel text checked. Ensure all controls and indicators operate correctly.

When all outstation tests are complete, network cable checks should be performed to ascertain correct operation by unplugging network cable to ensure the network is correctly fault monitoring and continues to work with a single cable fault.

When complete the log may be retrieved from Micro SD card, saved as a spreadsheet and kept for record purposes.

10 Maintenance

It is a requirement of BS 5839-9:2021 that a maintenance agreement be in place for the EVCS. The maintenance schedule should be as follows:

Frequency	Test
Weekly	Test a different outstation on the system each week and make a call to the control. Repeat each week until all outstations and master stations are tested. Record these results in the site log. If more than one master station is present alternate weekly.
Biannually	Engineer call to check system operation, intelligibility, field strength of attached AFILS equipment and check battery health. Record results and any variations into the site Log Book Copy all log files from the on-board Micro SD Card, and erase log directory before replacing card (to prevent out of memory errors)
Yearly	Engineer call to check system operation perform 100% outstation and master station operation, field strength of attached AFILS equipment and check battery health. Record results and any variations into the site Log Book
5 Yearly	In addition to Yearly tests replace all batteries and record in Log Book.

Technical Specification

Product Code	BMNET
Power Supply and Charger	
AC Input	230Vac+- 10% 50/60Hz
Internal power supply	12Vdc nominal
Supply and battery	Monitored open, Short, Fuses
Protection	Deep discharge, Short, Thermals
Temperature compensation	Yes
Battery information	1x 12V 7AH VRSLA
Mains fuse	1A HRC(T)
Battery fuse	Self Resetting PTC
Max charge current	500mA
Inputs	
Number of lines	Between 2 and 8
Remote enable	Short to use
End of line monitoring	10KΩ 0.5 watt resistor
Relay outputs	
Number and type	2: Fault and In use, volt free 30Vdc 1A
Controls	
Number and type	3 push button navigation keys
Indication	
Number and type	3x PSU Status Indicators 1 x CPU Fault Indicators 1x General Fault Indicator 1x RGB Mode Indicator 1x 272x480xRGB touchscreen
Enclosure Details	
Back box finish	RAL 7035 Grey
Dimensions	350 x 300 x 95
Entries	14 knockouts top, 2x rear slots
Flush Cutout	355 x 305 x 85 deep



Elite Security Products UK, Unit 7 Target Park, Shawbank Road, Lakeside, Redditch, Worcestershire, B98 8YN
Tel +44(0)1527 515 150, Fax +44(0)1527 150 143; Email info@espuk.com
Registered in England Number Company Registration No: 02769392, VAT Registration GB614686525

For more product information please visit www.espuk.com
E&OE - Errors and omissions excepted.K21

