

Product Overview



The Beacon Assist Call BACALM66 is a weatherproof call button, it is compatible with the Beacon B1M2/4/8, Beacon Network range of panels, Assist Call standalone 4 Zone, and the BAKIT & BABEDKIT kits.

This product can be used to replace a pull cord if agreed with all interested parties, note it only has visual indication.

Typical applications are shower rooms, en-suite bathrooms and wet changing areas.

This product has been tested to IP66 against dust particles and water jets when installed appropriately in accordance with these instructions and with all seals correctly positioned.

However, this product must not be immersed in water

Please ensure that you read all this guide prior to commencing installation

Installation



1. The unit should be mounted on a clean, rigid vertical surface suitable to accept screw fixings. The surface should be reasonably flat as unevenness could cause product damage or affect operation.

2. Remove the product cover from the base by removing the 4 Allen screws.

3. Remove the appropriate "cut out" suitable for your installation, ensuring that the "cut out" hole is not distorted, is clean and free from burrs.

4. For side, top or rear entry the lowermost drain hole must be drilled out using a 5mm drill.

- ONLY one drain hole position must be drilled.
- For bottom entry a drain hole MUST NOT be drilled in the rear box, but a drain hole MUST be drilled at the lowermost point of conduit run.
- For rear entry, remove rear knockout. For sealing protection, a channel around the knockout is provided to accept a bead of sealant (not supplied) when fixing to a mounting surface.

5. Mount the rear box using No 8 screws in all four, or at least two diagonal positions on fixing centres shown. The fixing holes are slotted to enable some rotation adjustment if required. Fit supplied bungs over all used fixing screw positions to seal aperture recesses.

6. Make cable entry into rear of box as required. Only remove blank plugs for required positions. Ensure adequate excess cable length for internal connections. Install & seal all cable glands & conduit to manufacturer's instructions. Ensure the gasket seal is properly fitted over front edge of rear box.

7. Connect the 2 cores to the Line + and 0 terminals there are 2 sets of 2-Part/removable terminals they are not marked in or out, it does not matter which is in or out, however polarity is important.

8. If the device is the last device in the circuit, then the EOL resistor should be fitted to the unused terminal if applicable.

9. Refit the 4 screws attaching the cover assembly to the base.

Drain Hole

Should the requirements of your installation require a drain hole to be opened, there are features for this provided in the base. Please cut out or use a 5 mm drill bit to open the drain hole at the bottom side of the base, as fitted, ensuring that you do not distort the base.

Opening the drain hole will compromise the IP rating of this product and particular care should be taken to ensure no water is directed at the drain hole once installed.

Cable Entries

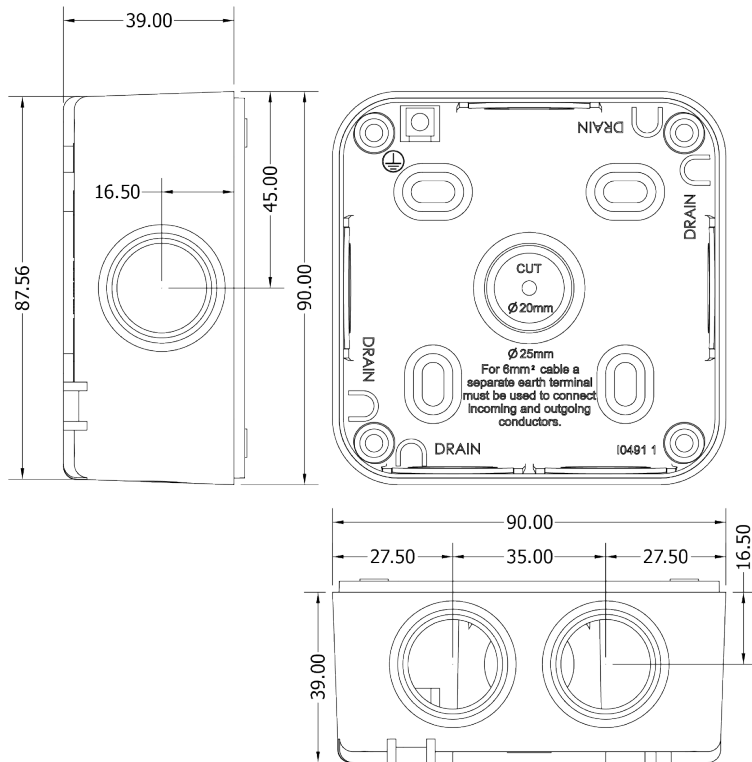

Cleaning

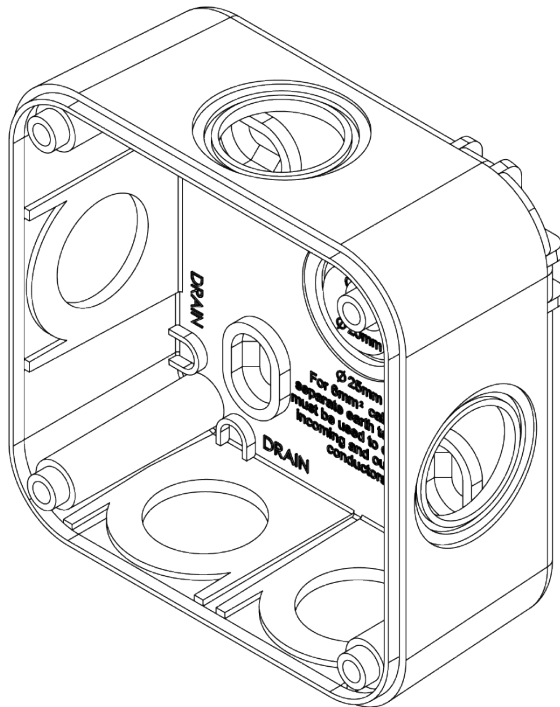

Over time environmental conditions/weathering may affect the stainless-steel finish of the product, this could be more severe on coastal regions. Due to this some discolouration may occur. It is recommended the surface is cleaned with a soft cloth soaked in neutral oil, such as WD-40®. Repeat this process up to 4 times per year.

