



www.espuk.com



EMDLED5WMBULK

5W LED IP65 Maintained Emergency Bulkhead

GENERAL INFORMATION

Our products are designed to comply with the recommended codes of practice for emergency lighting of premises and be installed by competent person in accordance with the relevant wiring regulations.

LUMINAIRE INFORMATION

Rated input supply: AC 240V 50Hz
Rated output power: 28 x SMD 2835 LED
Operating Environmental: Temperature:- 0-40 °C
Operating relative humidity: Less than 90%
Battery Specification: 3.6V 1800mAh NI-CAD Batteries
Emergency Duration: More than 3 Hours.
Change over time: Less than 1 second.

MONITORING

Green indicator lamp (LED) normally continuously 'on'. Indicator lamp goes out if A.C. supply or charger fails.



TEST RECORD SHEET

Table with columns for Month, Test, 1st year (Sign, Date), 2nd Year (Sign, Date), 3rd Year (Sign, Date), 4th Year (Sign, Date), and 5th year (Sign, Date). Rows 1-12 list functional test results.

Luminaire Type/Ref:

Date of Installation:

Location:

ESP Unit 7, Target Park, Shawbank Road, Lakeside, Redditch B98 8YN
Telephone: 01527 51 51 50
Fax: 01527 51 51 43
Email: info@espuk.com
www.espuk.com
E&OE - Errors and omissions excepted.



For additional product information please visit the ESP website www.espuk.com/technical_support/product_manuals/?cat=5

WARNING

- This product must be disconnected from the circuit if subjected to any high voltage or insulation resistance testing. Irreparable damage will occur if this instruction is not followed
- Recommended routine test procedure in accordance with BS 5266
- Daily check - check that the status GREEN LED indicator is illuminated
- Monthly functional test - simulate a mains supply failure for approx. 30 secs by operation of a key switch or circuit breaker. Ensure normal supply is restored after test and the indicator status LED is illuminated.
- Twice yearly conduct a one hour duration test - simulate a mains supply failure for one hour continuous test by operation of key switch or switching off circuit breaker. Ensure normal supply is restored after test and the indicator status LED is illuminated
- Annual full three hour duration test - conduct a three hour continuous duration test. Simulate a mains supply failure for three hour continuous test by operation of key switch or switching off circuit breaker. Ensure normal supply is restored after test and the indicator status LED is illuminated
- If the luminaire fails any of the above tests, please contact a qualified electrician. See overleaf for test record sheet

GENERAL

The LEDs fitted in this product are non-replaceable. The unit should be recycled in the correct manner when it reaches the end of its life. Check local authorities for where facilities exist. Clean with a soft dry cloth only, do not use aggressive cleaning products or solvents which may damage the fitting.

GENERAL INSTRUCTIONS

These instructions should be read carefully and retained after installation by the end user for future reference and maintenance.

SAFETY

- Installation of this luminaire should only be carried out by a qualified electrician or competent person to the current IEE Wiring Regulations
- Please isolate mains prior to installation/maintenance
- Check the total load on the circuit (including when this luminaire is fitted) does not exceed the rating of the circuit cable, fuse or circuit breaker
- Please note the IP (Ingress of Protection) rating of this luminaire when deciding the location for installation

INSTALLATION

- Provide power to the required point of installation. Suitable IP rated junctions boxes should be used where required
- Mark the location of the fixing holes and drill the holes ensuring not to infringe with any joists, gas or water pipes or electrical cables

- Remove two screws from the top of fitting (see Fig 1) to remove diffuser

- Pull apart tabs (see Fig 2) to gain access to the connections

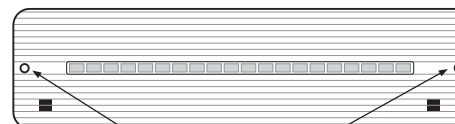

Fig 1 Remove screws

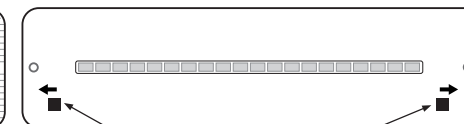

Fig 2 Pull apart tabs

- For non-maintained operation please wire up connector block as shown in Fig 3
- For maintained operation (luminaire always on) please see Fig 4

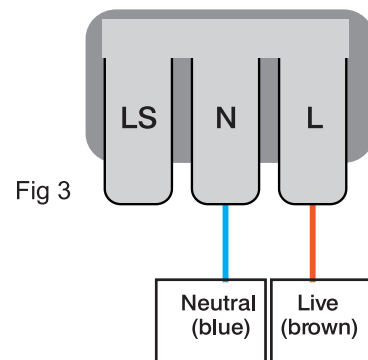

Fig 3

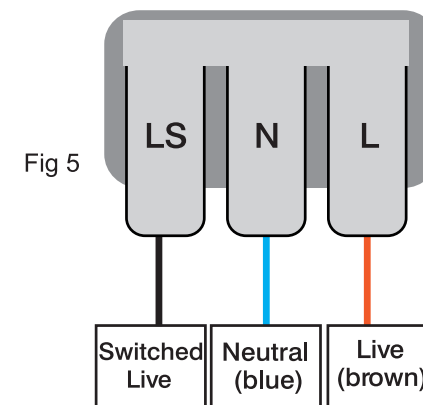

Fig 5

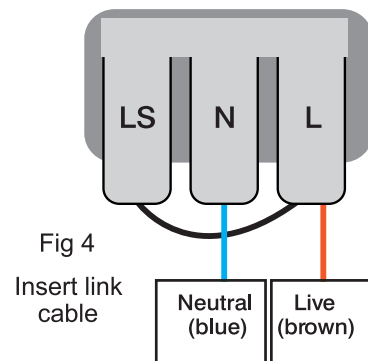

Fig 4

Insert link cable

- For switchable maintained operation see Fig 5
- Connect the battery via the plug and socket on the PCB
- Switch on the power supply and ensure the LED indicator is illuminated Green

- Switch on the power supply and ensure the LED status indicator is illuminated green to ensure the battery and supply are functioning. After 36 hours on continuous charge a mains failure should be simulated to ensure successful operation.