



www.espuk.com



EMD9WNMSPOT2

LED IP65 Non Maintained Emergency Twin Spot

GENERAL INFORMATION

Our products are designed to comply with the recommended codes of practice for emergency lighting of premises and be installed by competent person in accordance with the relevant wiring regulations.

LUMINAIRE INFORMATION

Rated input supply: AC 240V 50Hz
 Rated output power: 2 x 15 SMD 2835 LED Lamp
 Operating Environmental: Temperature:- 0-40 °C
 Operating relative humidity: Less than 90%
 Battery Specification: 9.6V 2200mAH NI-CAD Battery
 Emergency Duration: More than 3 Hours.
 Change over time: Less than 1 second.

MONITORING

Green indicator lamp (LED) normally continuously 'on'. Indicator lamp goes out if A.C. supply or charger fails.



For additional product information please visit the ESP website
www.espuk.com/technical_support/product_manuals/?cat=5

TEST RECORD SHEET

Month	Test	1st year		2nd Year		3rd Year		4th Year		5th year	
		Sign	Date	Sign	Date	Sign	Date	Sign	Date	Sign	Date
1	Functional										
2	Functional										
3	Functional										
4	Functional										
5	Functional										
6	1 hour										
7	Functional										
8	Functional										
9	Functional										
10	Functional										
11	Functional										
12	3 Hour										

Luminaire Type/Ref:

Date of Installation:

Location:

ESP Unit 7, Target Park,
 Shawbank Road, Lakeside,
 Redditch B98 8YN
 Telephone: 01527 51 51 50
 Fax: 01527 51 51 43
 Email: info@espuk.com
 www.espuk.com
 E&OE - Errors and omissions excepted.



WARNING

- This product must be disconnected from the circuit if subjected to any high voltage or insulation resistance testing. Irreparable damage will occur if this instruction is not followed
- Recommended routine test procedure in accordance with BS 5266
- Daily check - check that the status GREEN LED indicator is illuminated
- Monthly functional test - simulate a mains supply failure for approx. 30 secs by operation of a key switch or circuit breaker. Ensure normal supply is restored after test and the indicator status LED is illuminated.
- Twice yearly conduct a one hour duration test - simulate a mains supply failure for one hour continuous test by operation of key switch or switching off circuit breaker. Ensure normal supply is restored after test and the indicator status LED is illuminated
- Annual full three hour duration test - conduct a three hour continuous duration test. Simulate a mains supply failure for three hour continuous test by operation of key switch or switching off circuit breaker. Ensure normal supply is restored after test and the indicator status LED is illuminated
- If the luminaire fails any of the above tests, please contact a qualified electrician. See overleaf for test record sheet

GENERAL

The LEDs fitted in this product are non-replaceable. The unit should be recycled in the correct manner when it reaches the end of its life. Check local authorities for where facilities exist. Clean with a soft dry cloth only, do not use aggressive cleaning products or solvents which may damage the fitting.

GENERAL INSTRUCTIONS

These instructions should be read carefully and retained after installation by the end user for future reference and maintenance.

SAFETY

- Installation of this luminaire should only be carried out by a qualified electrician or competent person to the current IEE Wiring Regulations
- Please isolate mains prior to installation/maintenance
- Check the total load on the circuit (including when this luminaire is fitted) does not exceed the rating of the circuit cable, fuse or circuit breaker
- Please note the IP (Ingress of Protection) rating of this luminaire when deciding the location for installation

INSTALLATION

- 1) Lay fitting down and remove front panel.
- 2) Remove and discard packing pieces.
- 3) Fit unit to wall:

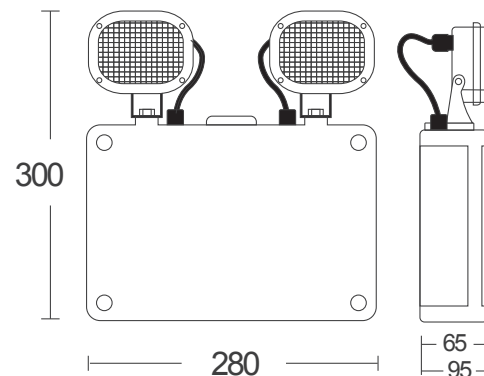

- 4) Connect the AC240V to the L.E.N. Terminal block.
- 5) Connect battery.
- 6) Refit front panel.
- 7) Switch on the mains supply, and two green indicator lamps should illuminate indicating that the unit is operational. If these indicators are not on, check connection of the battery and mains and ensure the lamp connections are secure.

The unit is fitted with deep discharge protection and this will operate when the battery voltage falls to approx 8V.

- Switch on the power supply and ensure the LED status indicator is illuminated green to ensure the battery and supply are functioning. After 36 hours on continuous charge a mains failure should be simulated to ensure successful operation.