



www.espuk.com

EMD5WNMDLK EM5WNMCDLK

LED 5W Emergency Open Lens Downlight

GENERAL INFORMATION

Our products are designed to comply with the recommended codes of practice for emergency lighting of premises and be installed by competent person in accordance with the relevant wiring regulations.

LUMINAIRE INFORMATION

Rated input supply: AC 240V 50Hz  
 Rated output power: 1 x 5W LED  
 Operating Environmental: Temperature:- 0-40 °C  
 Battery Specification : 4.8V 3500mAH Battery  
 Emergency Duration: More than 3 Hours.  
 Change over time: Less than 1 second.

MONITORING

Green indicator lamp (LED) normally continuously 'on'. Indicator lamp goes out if A.C. supply or charger fails.



TEST RECORD SHEET

Month	Test	1st year		2nd Year		3rd Year		4th Year		5th year	
		Sign	Date	Sign	Date	Sign	Date	Sign	Date	Sign	Date
1	Functional										
2	Functional										
3	Functional										
4	Functional										
5	Functional										
6	1 hour										
7	Functional										
8	Functional										
9	Functional										
10	Functional										
11	Functional										
12	3 Hour										

Luminaire Type/Ref:

Date of Installation:

Location:

ESP Unit 7, Target Park,  
 Shawbank Road, Lakeside,  
 Redditch B98 8YN  
 Telephone: 01527 51 51 50  
 Fax: 01527 51 51 43  
 Email: info@espuk.com  
 www.espuk.com  
 E&OE - Errors and omissions excepted.



For additional product information please visit the ESP website  
[www.espuk.com/technical\\_support/product\\_manuals/?cat=5](http://www.espuk.com/technical_support/product_manuals/?cat=5)

### WARNING

- This product must be disconnected from the circuit if subjected to any high voltage or insulation resistance testing. Irreparable damage will occur if this instruction is not followed
- Recommended routine test procedure in accordance with BS 5266
- Daily check - check that the status GREEN LED indicator is illuminated
- Monthly functional test - simulate a mains supply failure for approx. 30 secs by operation of a key switch or circuit breaker. Ensure normal supply is restored after test and the indicator status LED is illuminated.
- Twice yearly conduct a one hour duration test - simulate a mains supply failure for one hour continuous test by operation of key switch or switching off circuit breaker. Ensure normal supply is restored after test and the indicator status LED is illuminated
- Annual full three hour duration test - conduct a three hour continuous duration test. Simulate a mains supply failure for three hour continuous test by operation of key switch or switching off circuit breaker. Ensure normal supply is restored after test and the indicator status LED is illuminated
- If the luminaire fails any of the above tests, please contact a qualified electrician. See overleaf for test record sheet

### GENERAL

The LEDs fitted in this product are non-replaceable. The unit should be recycled in the correct manner when it reaches the end of its life. Check local authorities for where facilities exist. Clean with a soft dry cloth only, do not use aggressive cleaning products or solvents which may damage the fitting.

### GENERAL INSTRUCTIONS

These instructions should be read carefully and retained after installation by the end user for future reference and maintenance.

### SAFETY

- Installation of this luminaire should only be carried out by a qualified electrician or competent person to the current IEE Wiring Regulations
- Please isolate mains prior to installation/maintenance
- Check the total load on the circuit (including when this luminaire is fitted) does not exceed the rating of the circuit cable, fuse or circuit breaker
- Please note the IP (Ingress of Protection) rating of this luminaire when deciding the location for installation

### INSTALLATION

INPUT 220-240VAC  
50/60 Hz

BATTERY  
CONNECTING LINE

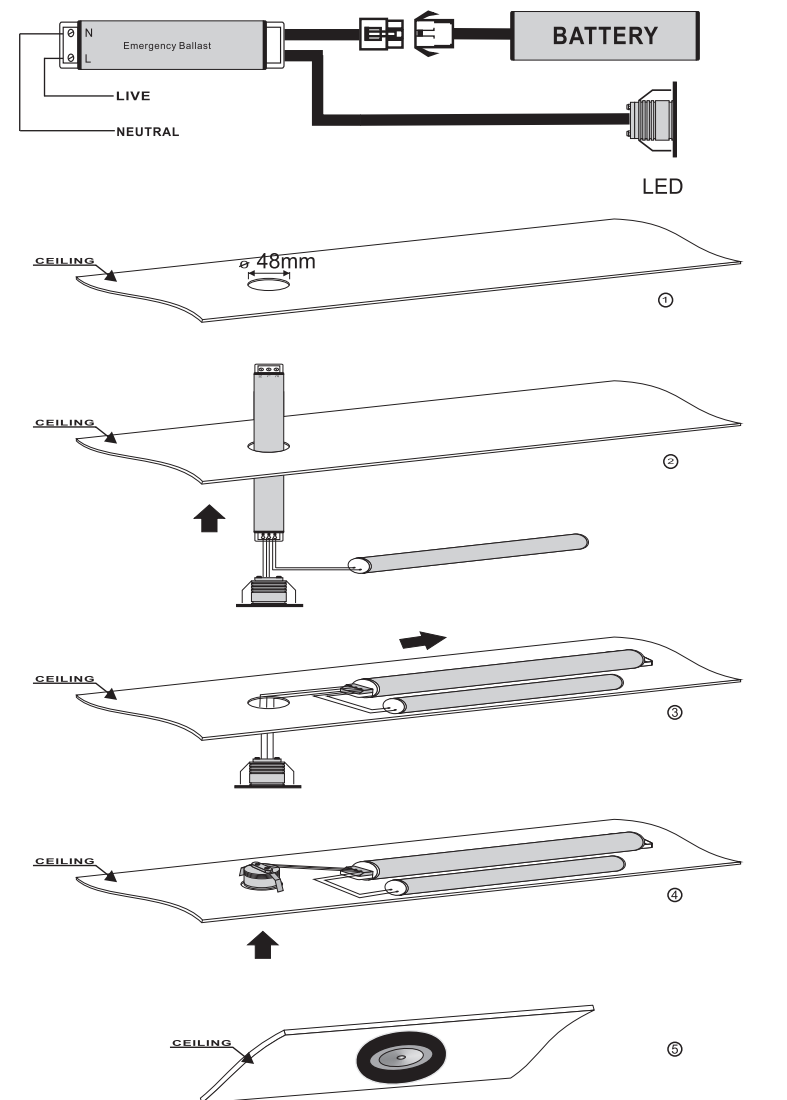

Switch on the power supply and ensure the LED status indicator is illuminated green to ensure the battery and supply are functioning. After 36 hours on continuous charge a mains failure should be simulated to ensure successful operation.