



D5010WH

Duceri Emergency Self Test Bulkhead 3W LED IP65 Lithium Battery Maintained White

GENERAL INFORMATION

Our products are designed to comply with the recommended codes of practice for emergency lighting of premises and be installed by competent person in accordance with the relevant wiring regulations.

LUMINAIRE INFORMATION

Rated Input Supply: AC 240V 50Hz
 Rated Output Power: 8 x SMD LED 2835
 Operating Temperature: 0-45°C
 Operating Relative Humidity: Less than 90%
 Battery Specification: 3.2V 1500mAh LiFePO4 Battery
 Emergency Duration: More than 3 Hours
 Change Over Time: Less than 1 second.

MONITORING:

Green indicator lamp (LED) normally continuously 'on'. Indicator lamp goes out if AC supply or charger fails.



The latest product manuals and software is available online:
https://www.espuk.com/technical_support

Test Record Sheet

Month	Test	1st Year		2nd Year		3rd Year		4th Year		5th Year	
		Sign	Date	Sign	Date	Sign	Date	Sign	Date	Sign	Date
1	Functional										
2	Functional										
3	Functional										
4	Functional										
5	Functional										
6	1 Hour										
7	Functional										
8	Functional										
9	Functional										
10	Functional										
11	Functional										
12	3 Hour										

Luminaire Type/Ref:

Date of Installation:

Location:

WARNING

- This product must be disconnected from the circuit if subjected to any high voltage or insulation resistance testing. Irreparable damage will occur if this instruction is not followed
- Recommended routine test procedure in accordance with BS 5266
- Daily check - check that the status GREEN LED indicator is illuminated
- Monthly functional test - simulate a mains supply failure for approx. 30 secs by operation of a key switch or circuit breaker. Ensure normal supply is restored after test and the indicator status LED is illuminated.
- Twice yearly conduct a one hour duration test - simulate a mains supply failure for one hour continuous test by operation of key switch or switching off circuit breaker. Ensure normal supply is restored after test and the indicator status LED is illuminated
- Annual full three hour duration test - conduct a three hour continuous duration test. Simulate a mains supply failure for three hour continuous test by operation of key switch or switching off circuit breaker. Ensure normal supply is restored after test and the indicator status LED is illuminated
- If the luminaire fails any of the above tests, please contact a qualified electrician. See overleaf for test record sheet
- **Switch on the power supply and ensure the LED status indicator is illuminated green to ensure the battery and supply are functioning. After 36 hours on continuous charge, a full battery discharge should occur. This will ensure correct battery reset, once batteries are fully depleted, mains power should be reapplied to the system. Normal maintenance procedures should occur once mains power has been reapplied.**

GENERAL

The LEDs fitted in this product are non-replaceable. The unit should be recycled in the correct manner when it reaches the end of its life. Check local authorities for where facilities exist. Clean with a soft dry cloth only, do not use aggressive cleaning products or solvents which may damage the fitting.

GENERAL INSTRUCTIONS

These instructions should be read carefully and retained after installation by the end user for future reference and maintenance.

SAFETY

- Installation of this luminaire should only be carried out by a qualified electrician or competent person to the current IEE Wiring Regulations
- Please isolate mains prior to installation/maintenance
- Check the total load on the circuit (including when this luminaire is fitted) does not exceed the rating of the circuit cable, fuse or circuit breaker
- Please note the IP (Ingress of Protection) rating of this luminaire when deciding the location for installation

INSTALLATION

- Provide power to the required point of installation. Suitable IP rated junctions boxes should be used where required
- Mark the location of the fixing holes and drill the holes ensuring not to infringe with any joists, gas or water pipes or electrical cables

- Remove two screws from the top of fitting (see Fig 1) to remove diffuser

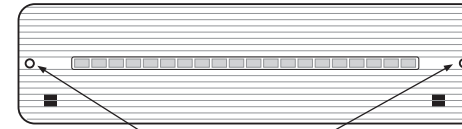

Fig 1 Remove screws

- Pull apart tabs (see Fig 2) to gain access to the connections

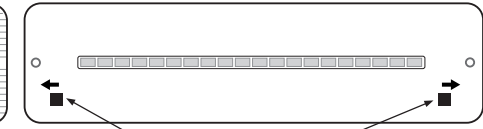

Fig 2 Pull apart tabs

- For non-maintained operation please wire up connector block as shown in Fig 3
- For maintained operation (luminaire always on) please see Fig 4

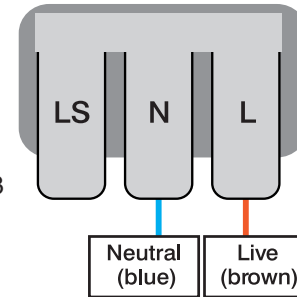

Fig 3

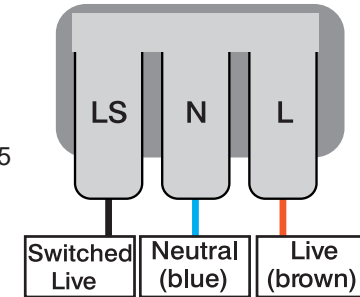

Fig 5

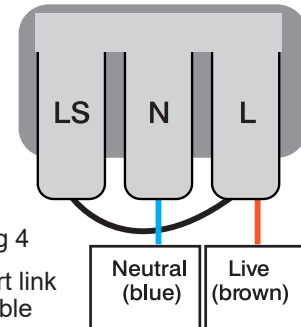

Fig 4
Insert link
cable

- For switchable maintained operation see Fig 5
- Connect the battery via the plug and socket on the PCB
- Switch on the power supply and ensure the LED indicator is illuminated Green