



D1101WH & D1101BK

Duceri Emergency Twin Spot 6W LED IP40 Lithium Battery Non-Maintained

GENERAL INFORMATION

Our products are designed to comply with the recommended codes of practice for emergency lighting of premises and be installed by competent person in accordance with the relevant wiring regulations.

LUMINAIRE INFORMATION

Rated Input Supply: AC 240V 50Hz
 Rated Output Power: 2 Heads; 6 x SMD LED 2835
 Operating Temperature: 0-45°C
 Operating Relative Humidity: Less than 90%
 Battery Specification: 3.2V 6000mAh LiFePO4 Battery
 Emergency Duration: More than 3 Hours
 Change Over Time: Less than 1 second.

MONITORING:

Green indicator lamp (LED) normally continuously 'on'. Indicator lamp goes out if AC supply or charger fails.

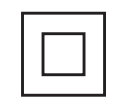

The latest product manuals and software is available online:
https://www.espuk.com/technical_support

Test Record Sheet

Month	Test	1st Year		2nd Year		3rd Year		4th Year		5th Year	
		Sign	Date	Sign	Date	Sign	Date	Sign	Date	Sign	Date
1	Functional										
2	Functional										
3	Functional										
4	Functional										
5	Functional										
6	1 Hour										
7	Functional										
8	Functional										
9	Functional										
10	Functional										
11	Functional										
12	3 Hour										

Luminaire Type/Ref:

Date of Installation:

Location:

INSTALLATION OF THE FITTING

- 1) Lay fitting on its back and remove front panel.
- 2) Remove and discard packing pieces.
- 3) Fit unit to wall:

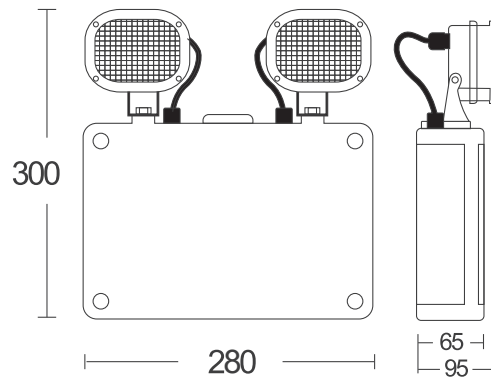

- 4) Connect the AC240V to the L.E.N. Terminal block.
- 5) Connect battery.
- 6) Refit front panel.
- 7) **Switch on the power supply and ensure the LED status indicator is illuminated green to ensure the battery and supply are functioning.**
After 36 hours on continuous charge, a full battery discharge should occur. This will ensure correct battery reset, once batteries are fully depleted, mains power should be reapplied to the system.
Normal maintenance procedures should occur once mains power has been reapplied.

FAULT FINDING AND CORRECTIVE ACTION

MONITORING LED NOT ILLUMINATED

A.C. supply not healthy. Battery not connected. Charger failed.

UNIT NOT MEETING REQUIRED EMERGENCY PERIOD

may need cycling: Discharge then, recharge for full 24 hours. Retest, battery may need replacing if emergency duration is still not met.

LAMP NOT ILLUMINATED

If illumination is hesitant and of a low level, either the battery or (less likely) the printed circuit board needs replacing.

RECOMMENDED ROUTINE TEST PROCEDURE

The following test is designed to ensure the continued protection of your premises and occupants. Because of the possibility of a failure of the normal lighting supply occurring shortly after a period of testing, all tests should whenever possible, be undertaken at times of least risk, e.g during daylight hours.

ONCE A DAY

Visual inspection of battery charge led.

ONCE A MONTH

Each unit should be energised from its battery for about 30 seconds by simulation of a failure of the normal lighting supply, to ensure the lamp operates in the emergency condition.

TWICE A YEAR

Each unit should be energized from its battery for a continuous period of at least one hour. Inspect the halogen lamps. It is recommended that for luminaires the lamps are replaced at intervals of no more than 1 year in order to retain the design photometric characteristics.

AFTER THREE YEARS & EACH SUBSEQUENT YEAR

All units with specified durations in excess of 1 hour should be energised for their full rating period.