

# ENTERVIEW VX

DOOR STATION WITH PROXIMITY READER



[www.espuuk.com](http://www.espuuk.com)

# Table of contents

- Planning and installing the Enterview VX ..... 3
- Wiring Diagram ..... 5
- Fitting the external call station ..... 6
- Fitting and wiring the handset ..... 7
- Programming the Enterview VX proximity reader ..... 9
- Troubleshooting guide ..... 11
- Optional accessories for Enterview VX ..... 12



**EVVX1PRF**  
1 button proximity flush mount video door station



**EVVX1PRS**  
1 button proximity surface mount video door station

# Planning and installing the Enterview VX

## External call station

- How many Entry Doors (Front or/and Rear)
- Mounting: flush or surface.

## Equipment required

- External call station (one required per door)
- Maximum of 4 call buttons
- External call station power supply DC 12 volts (EVBPS) (one required per door)
- Handset EV5H/EV5HF (minimum of one per external call button)  
The maximum distance per supplied power supply to each handset is 10 meters using 2 pairs of CAT5e cable.
- Electric lock magnetic (ML250)/Yale type (ENTERD)
- CAT5e cable minimum 4 cores (see Note above regarding cable distances)
- Push to exit button (one required per door if magnetic lock used)
- Emergency break glass (One required per door if magnetic lock used and the door is deemed an emergency exit)
- Combined timed lock and outdoor call station power supply (EVBPS)

Note: The maximum cable distance from the external panel to each internal handset is 100 meters using CAT5e cable.

## Handsets

- Audio/video handsets: a minimum of one per external call button/ a maximum of 4 video door entry handsets and 2 audio only handsets.
- Each handset requires the supplied power supply.

## Door Gear

- Power supply with timed output (EVBPS)
- Magnetic lock or Yale type lock
- Push to exit button and emergency break glass (only needed when magnetic lock fitted to an emergency exit door)

## **Basic cabling**

- 240 VAC mains feed to external door and lock control power supply (EVBPS)
- 240 VAC mains feed to each handset (via transformer- supplied)
- 4 core from each external call station (front/rear) to its own power supply (EVBPS)
- CAT5e from each external call station (front/rear) to each handset
- 4 core from push to exit button to EVBPS (power supply)
- 4 core from lock to EVBPS (power supply)
- 4 core from EVBPS (power supply) to emergency break glass (if fitted)
- 2 pairs of CAT5e from supplied power supply to each handset

Note: The maximum cable distance from the external panel to each internal handset is 100 meters using CAT5e cable. The maximum distance per supplied power supply to each handset is 10 meters using 2 pairs of CAT5e cable.

# Wiring diagram

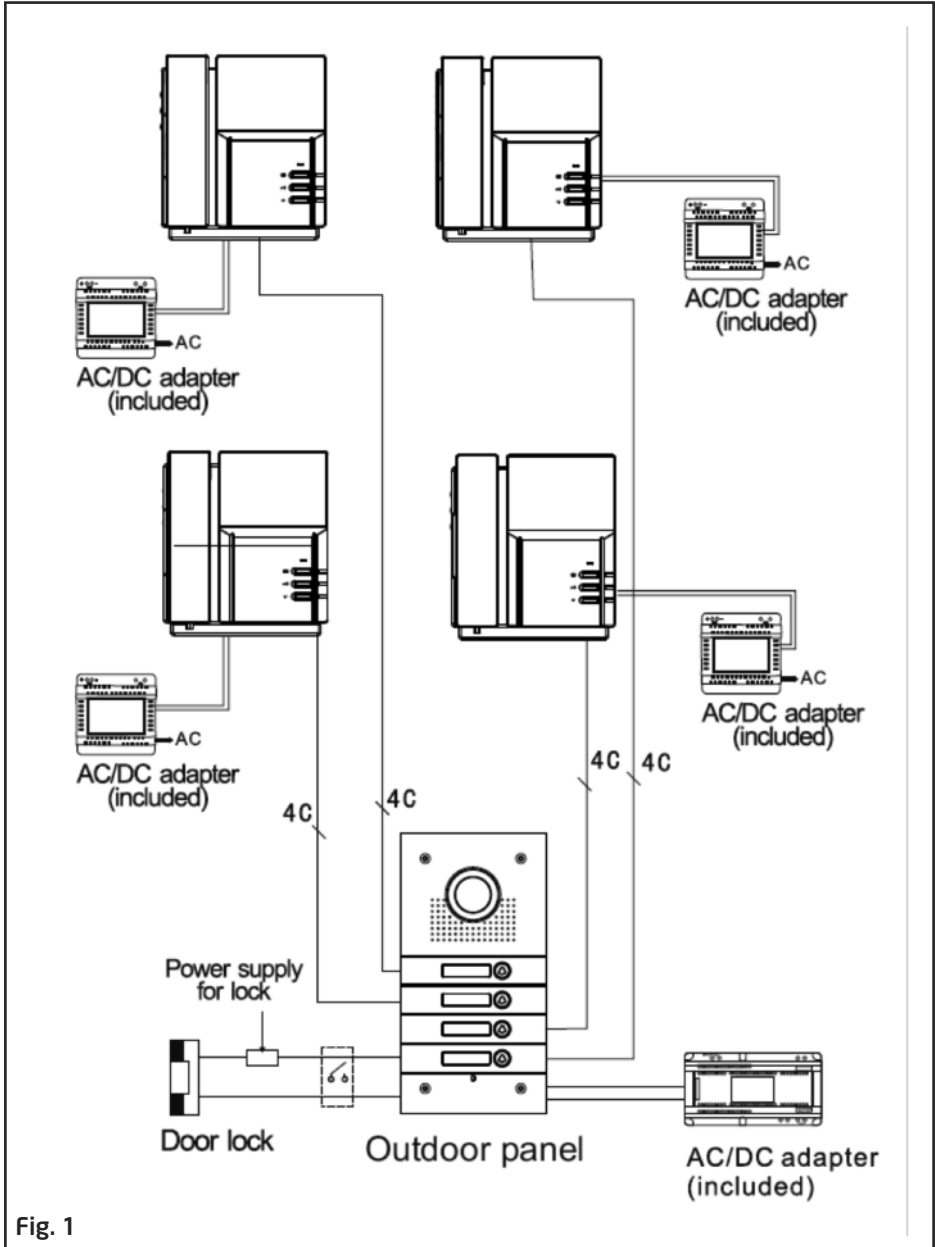

## Fitting the external call station

- Select a location close to the door to be controlled
- Recommended mounting height 1.45 meters (camera lens)
- Secure back plate to the wall paying attention to the upward facing arrow located on the back plate
- Feed cables from each apartment and the power supply through the cable entry hole, the entry hole will need to be knocked out.

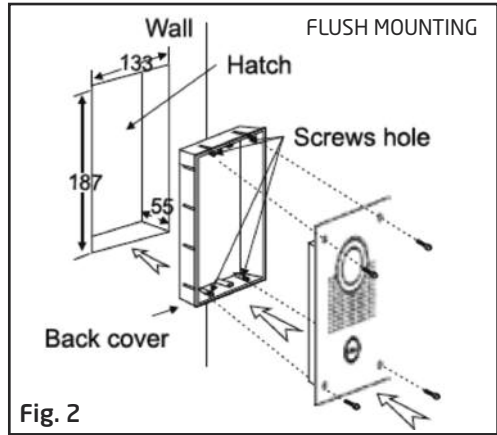

### Wiring the external call station

- Each call button will have its own brown 4 core connector (supplied) consisting of red, blue, yellow and white cores.
- The 4 colours that are connected to the brown connector are to be connected to the corresponding 4 core cable going to each of the apartments.
- The connection can be completed by means of soldering, crimping or by use of screw connectors.
- To power the camera, keypad and call station a 12 volt DC feed is required. To do this a white two pin plug consisting of red and black cores supplied should be connected to the corresponding cable going to the EVBPS power supply.
- The two single black cables on the external call station are for the lock release. These are volt free and are normally open going closed. These contacts will change state on the lock release command. The two black cables need to be connected the EVBPS 'p.b' terminal

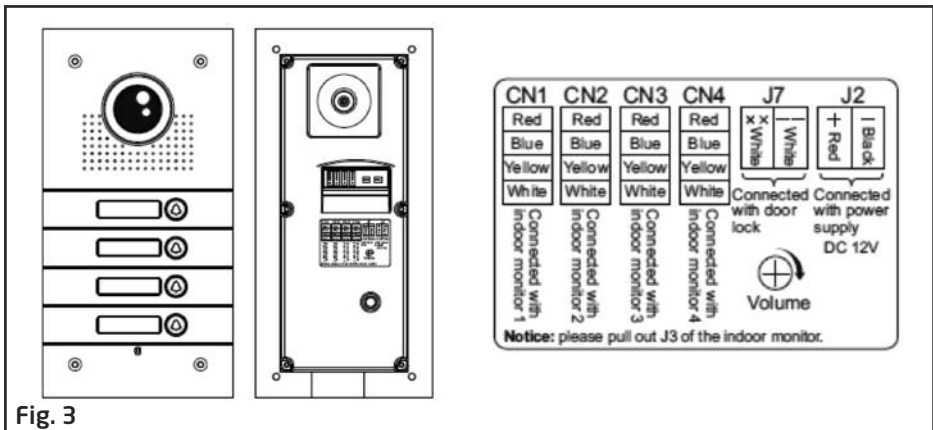

## Removing name tag

To remove name tag:

- 1) Push in name tag on the left-hand side
- 2) Slide name tag from right to left

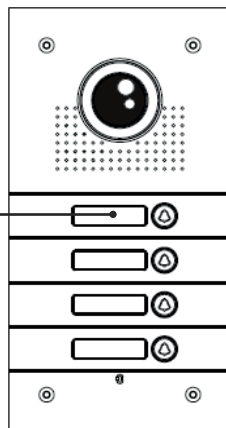

## Fitting and wiring the handset

- On all types of handsets fitted to a EVVX system please remove the jumper labeled J3. This can be found next to the connecting plugs on the rear.
- Locate the metal back plate and observe the arrow and the word up.
- Fit mounting plate to the selected location, recommended mounting height 1.45m
- Feed the cable from the local transformer and the external call button though the center opening
- Connect the corresponding cores from the external call button cable to the brown plug (supplied) consisting of red, blue, yellow and white cores.
- Once connected, fit the brown plug into the rear of the handset socket CN1 for call station one and CN2 for external call station two.
- Connect the corresponding cores from the transformer to the white plug (supplied) consisting of red and black cores.
- Once connected, fit the white plug into the rear of the handset socket marked 5 (+) and 6

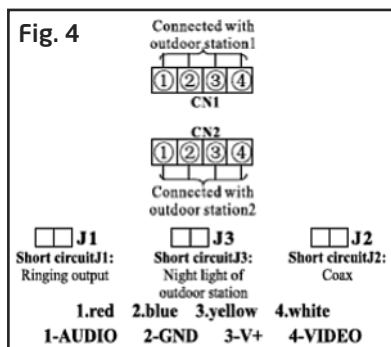

Note: J1 and J2 are not used. Remove J3 on all handsets for multiway capability.

Fig. 5

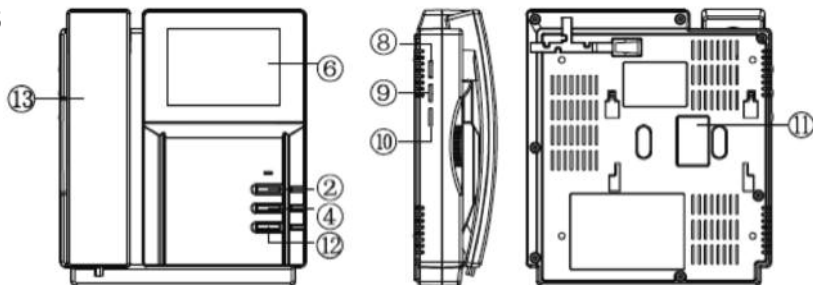

Dimension: 220x110x28(mm)

Fig. 6

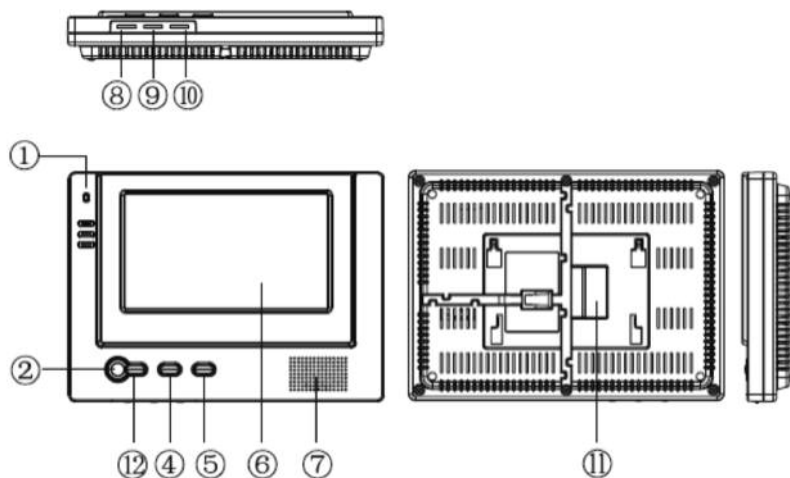

Dimension: 240X175X38(mm)

NO	Icon	Description	NO	Icon	Description
①		Microphone	⑧	☞	Talking volume
②	📺	Monitor	⑨	☼	Brightness
③	🔌	Hang off	⑩	◊	Chroma/contrast
④	🔓	Door lock releasing	⑪		System terminal
⑤	🗣️	Talking	⑫	⦿	Calling
⑥		TFT display/CRT	⑬		Receiver
⑦		Speaker	⑭		Indicated light



### Fitting the handset to the bracket

- Locate the 4 lugs on the metal back plate, one located on each corner see Fig. 7, these lugs must fit into the recesses on the rear of the hand set.
- Place the handset over the metal back plate keeping the cables flat and out of the way of the lugs.
- Slide the hand set down into position engaging the 4 lugs on the back plate into the recesses of the hand set.

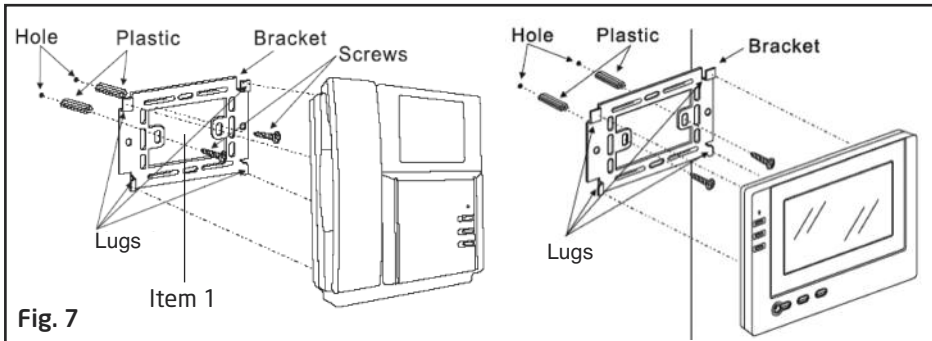

## Programming the Enterview VX Proximity Reader

**All system programming requires the EVVX remote control. System programming cannot be performed without it.**

To enter programming mode press \* # followed by the 4 digit programming code (The factory default programming code: 4567) followed by #, the indication light on the reader will change from red to amber and a long single confirmation tone will be heard.

**It is mandatory to keep an on-site record of which user holds possession of which numbered card/tag and what location number it is registered to. A card/tag cannot be deleted from the system if the location number or the whereabouts of the card/tag are unknown.**

### Adding User Cards/Tags using the card/tag numbers

- Enter programming mode.
- Press 1 - a single confirmation tone will be heard
- Enter the last 6 digits of the new card/tag to be added, a single confirmation tone will be heard.

To add further cards simply enter the last 6 digits of the next card.

If the error tone is emitted (4x beeps), this indicates that this card/tag is already registered

- Press the \*\* key to exit programming mode.

### Adding User Cards/Tags by swiping

- Enter programming mode.
- Press 1 - a single confirmation tone will be heard

- Swipe the new card/tag to be added, a double confirmation tone will be heard.  
To add further cards simply swipe the next card/tag.  
If the error tone is emitted (4x beeps), this indicates that this card/tag is already registered
- Press the \*\* key to exit programming mode.

### **Deleting user cards/tags**

Enter programming mode.

- Press 2 - a single confirmation tone will be heard
- Enter the last 6 digits of the new card/tag to be deleted, a single confirmation tone will be heard.  
To delete further cards simply enter the last 6 digits of the next card/tag.  
If the error tone is emitted (4x beeps), this indicates that this card/tag is already deleted
- Press the \*\* key to exit programming mode.

### **Deleting User Cards/Tags by swiping**

- Enter programming mode.
- Press 2 - a single confirmation tone will be heard
- Swipe the new card/tag to be deleted, a double confirmation tone will be heard.  
To delete further cards simply swipe the next card/tag.  
If the error tone is emitted (4x beeps), this indicates that this card/tag is already deleted
- Press the \*\* key to exit programming mode.

### **Deleting all user cards/tags**

- Enter programming mode.
- Press 9 - a single confirmation tone will be heard.
- Press 9 again - a double confirmation tone will be heard, once this tone stops the 'delete all' command is complete.
- Press the \*\* key to exit programming mode.

### **Setting the Unlock time**

Factory default door open time is set at 05 seconds.

- Enter programming mode.
- Press 4 - a single confirmation tone will be heard
- Enter the desired lock/relay operation time in a two digit format (01 to 99 seconds) - a double confirmation tone will be heard.  
The Unlock time is now changed.
- Press the \*\* key to exit programming mode.

### **Changing the programming code**

- Factory default pin 4567.
- Enter programming mode.
- Press 8 - a single confirmation tone will be heard.
- Enter the new 4 digit programming code and press # - a single confirmation tone will be heard.
- Re-enter the new 4 digit programming code and press # - a double confirmation tone will be heard.
- Press the \*\* key to exit programming mode.

## **Reset a forgotten programming code**

- Turn-off power for 60seconds
- Turn-on power again and press # for 3 seconds - a single confirmation tone will be heard. Code is now reset to factory default.

## **Trouble Shooting Guide**

### **No picture appears on the monitor (blue or white screen)**

- Check that all wires are connected and connected in the correct configuration
- Check that the voltage at the back of the monitor across terminals 5 and 6. The voltage should be over 14.3vDC, if it is not then the handset will not function correctly

### **One or more monitors are not working but others are**

- Check that all wires are connected and connected in the correct configuration
- Swap the monitor positions around. This will identify if the issue lies with the monitor or the location of the monitor. For example - monitor 1 does not work, monitor 2 does, when swapped around monitor 1 works in monitor 2's location. There is a problem with monitor 2's location (wiring problem etc)

### **If no monitors work**

- Check that power is supplied to each monitor and that the specifications for installation have been followed correctly
- Check that all wires are connected and connected in the correct configuration
- Run a new length of short cable and connect a monitor next to the camera, this will rule out any issue with lack of voltage and/or cable run length. The PSU's supplied with each monitor must be used and the cable length from PSU to monitor must not exceed 10m

### **In multi apartment systems if more than one apartments monitor rings simultaneously**

- Remove jumper J3 from all handsets

### **Please also check**

- The monitor and the outdoor station connections are colour coded - ensure the colours are matched
- Connect to the CN1 terminal on the back of the handset for a single outdoor station system
- Connect to the CN2 terminal on the back of the handset if a 2nd outdoor station is used

### **The electro-magnetic lock (MAGLOCK) will not energise**

- The electro-magnetic lock (MAGLOCK) requires 12vDC to lock. Trace the 12vDC from the lock to the power supply source and test that sufficient power is reaching the lock

### **If using the EVBPS**

- Please ensure that the N.C switch is in position for an electro-magnetic lock release
- Please ensure that the N.O switch is in position for a Yale style lock release

### **The electro-magnetic lock (MAGLOCK) does not have enough holding force**

- Check the voltage and ensure that the rubber washer has been fitted along with the armature, this will enable enough movement for the magnet and armature to line-up correctly as the movement allowed compensates for misalignments on the door / frame

# Optional accessories for Interview VX



## EVH5C-HF - Hands Free Colour Handset

- High resolution colour 7" monitor
- Door release button
- Up to 3 additional handsets per system



## EVH5C - Colour Handset

- High resolution colour 4" monitor
- Door release button
- Up to 3 additional handsets per system



## EVHF10W and EVHF10B - Colour handsfree 10" monitor

- High resolution colour 10" monitor
- Contemporary black or white design
- Door release button
- Two camera input



## EVH5A0 - Audio only handset

- Clear high quality audio
- Door release button
- Up to two per system



## EVBPS - Boxed power supply for use with lock release

- 100-240vAC, 50/60Hz input
- 1.5A /12vDC output (NO/NC selectable)
- 1A 12vDC output
- Size: 129 x 73 x 50mm LwD



## EV-ML-250 - Electromagnetic Lock

- Holding force 250kg/550lbs max
- 420ma 12vdc input
- Z & L mounting bracket included
- NB. Requires EV-BPS power supply



## EV-EXIT - Push to Exit Lock release button

- Stainless steel fascia
- Flush mounting (back box included)
- Push to make contacts



## EV-EBG - Emergency Break Glass

- Surface mounted
- Emergency break glass to release door



## ENTERD - Electromagnetic Lock

- Holding force 295kg/650lbs
- 160ma 12vdc input
- For use with Yale type rim locks
- Surface mounting version available
- NB. Requires EV-BPS power supply

Elite Security Products  
Unit 7, Target Park, Shawbank Rd  
Lakeside, Redditch B98 8YN



Telephone: 01527 515150  
email: info@espuk.com