

# A1IPDSM1

## Full Manual

Aperta IP PoE Multi Way Outdoor Station IP65 HD  
with Proximity Reader



The latest product manuals and software is available online:  
[https://www.espuk.com/technical\\_support](https://www.espuk.com/technical_support)



## Contents

<b>1. Installation</b>	<b>Page 1</b>
<b>2. Main Interface</b>	<b>Page 2</b>
<b>3. Video Intercom</b>	<b>Page 2</b>
<b>4. Unlock Functions</b>	<b>Page 3</b>
A. Public Password Unlock	Page 3
B. User Password Unlock	Page 3
C. Proximity Card/Fob Unlock	Page 3
<b>5. System Settings</b>	<b>Page 4</b>
1. Setting the Address	Page 4
2. Setting the Administrator Password	Page 4
3. Setting the Public Password	Page 5
4. Password Authority	Page 5
5. Volume Setting	Page 5
6. Unlock Type	Page 6
7. Sensor Setting	Page 6
8. Language Setting	Page 6
9. Date Setting	Page 7
10. System Information	Page 7
11. Card Management	Page 7 - 9
12. Restore Default Settings	Page 9
13. Trade Hours	Page 9
<b>6. Installation of Outdoor Units</b>	<b>Page 10</b>

# 1. Installation

Connect the Door Station to a switch/network or alternatively directly to a Monitor using the RJ45 port [1].

If the connected network does not support PoE, then DC12V1A needs to be applied to the 12V & GND terminals [2].

\*All system cabling has been tested with Cat5E UTP PVC Cable.

\*\*Maximum distance of 100m to PoE switch is supported.

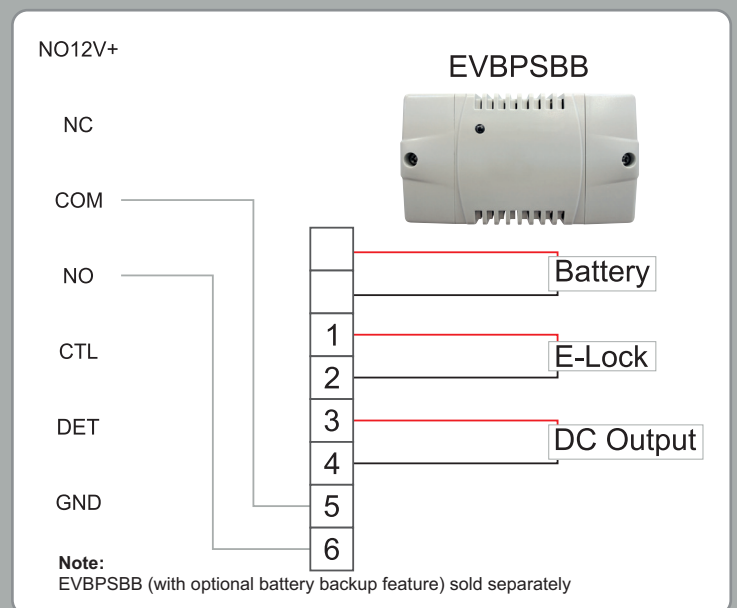
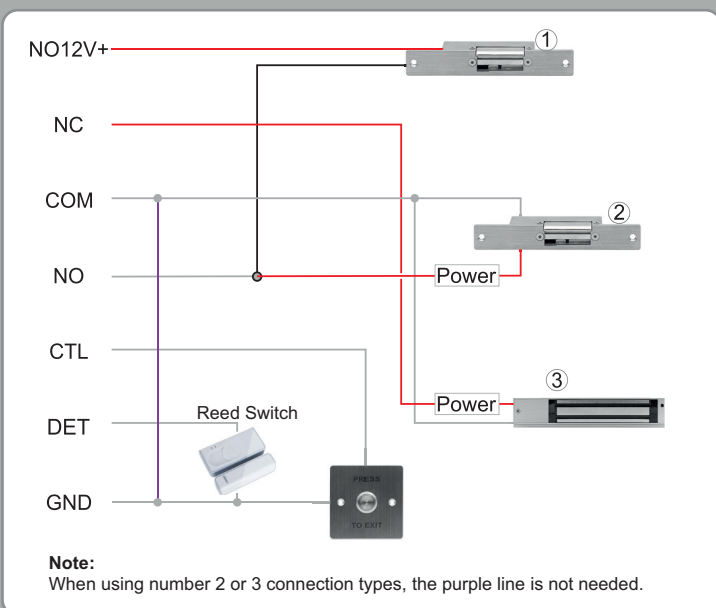
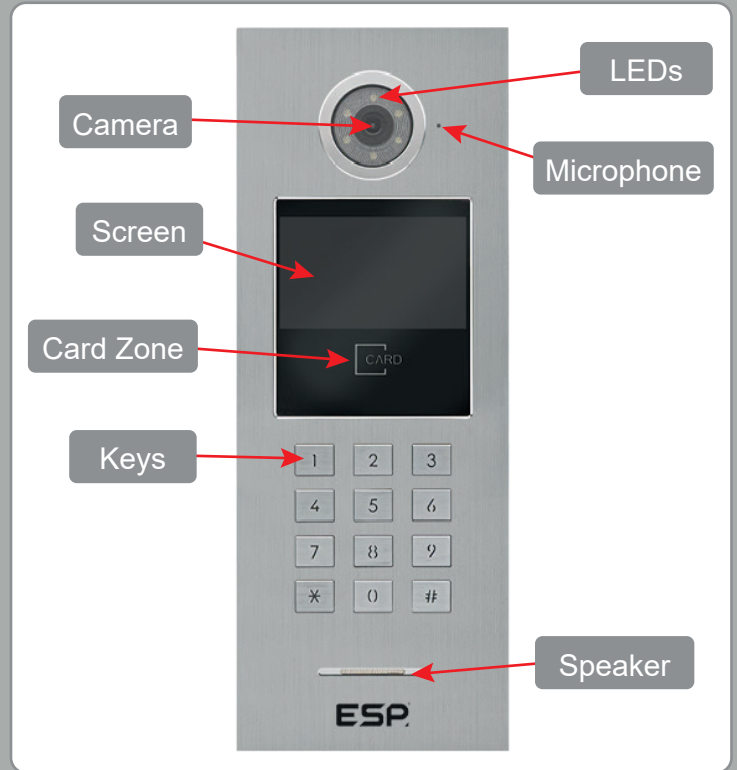
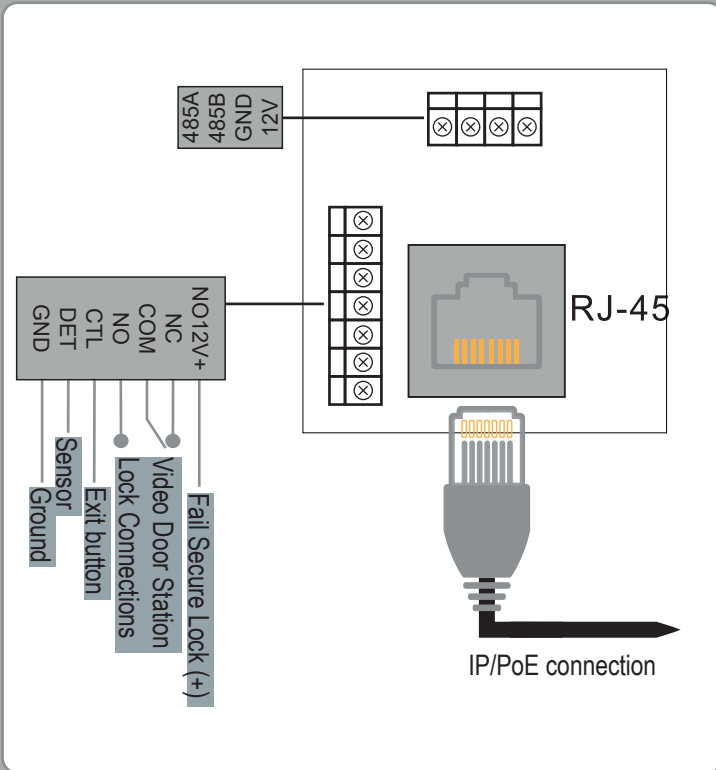

## 2. The Main Interface

On standby, the display will show Date & Time, Network Status, Visitor's Calling, Password Unlocking, and User Instructions.

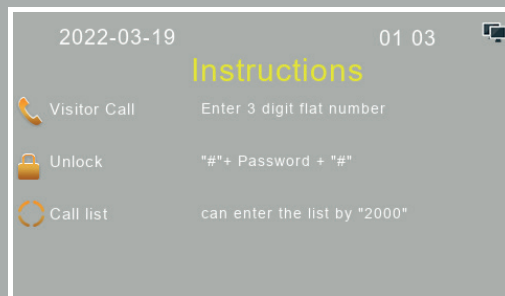

## 3. Video Intercom

1. In the main interface, visitors input the Room Number, eg: input 101 or 0101, the three digit room no. call after 3 seconds, the four digits Room Number call immediately.

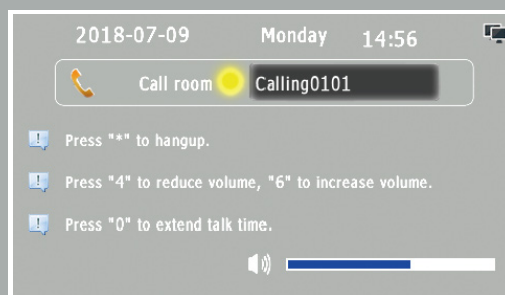

2. When entering a Room Number, press \* to delete any errors; During calling or talking, press "\*" to end the call.

During the conversation, press "4" key low down volume, "6" key rise up volume, press "0" to extend the conversation time to be 60 seconds.

3. When entering the Room Number, press "\*" to delete any errors;

During a call or when calling, press "\*" to end the call.

During the conversation, pressing "4" will lower the volume, pressing "6" will raise the volume

4. The Indications of the Status Bar are:

1. Calling - Outdoor Station Calling Indoor Monitor
2. Busy - Indoor Monitor Busy
3. Connected- Intercom

5. If a monitor when connected to a call, and the monitor's unlock feature is used, the Outdoor Station will show "Door Unlock".

## 4. Unlock Functions

### A. Public Password Unlock

Public unlock passwords by default are disabled. It will need to be set by the responsible person to set the password. To use the Public Password; Press “#” + “Public Password” + “#”.

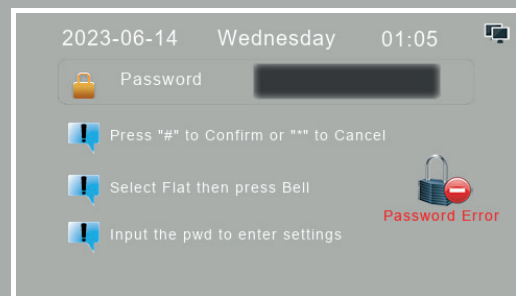
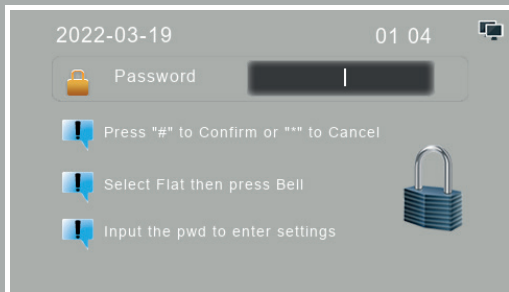

### B. User Password Unlock

Public unlock passwords by default are disabled. It will need to be set by the responsible person to set the password.

To use the User Password; Press “\*” + Room Number + “#” + “User Password” + “#”

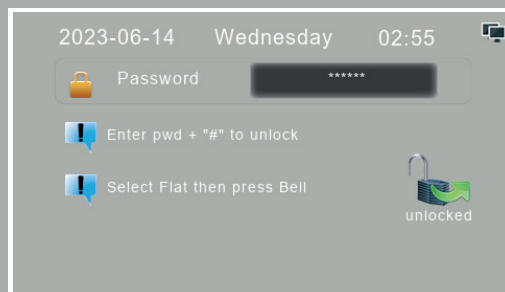

### C. Proximity Card/Fob Unlock

Simply Present the Programmed Card to the “Card Zone”.

## 5. System Settings

### Enter administration mode:

Press (when in standby) # to enter the password entry screen, then type in the **Administration Passcode**, and then press #.

Once into Administration mode, pressing “#” will confirm or enter a submenu, “4” will navigate left, “6” will navigate right, and “\*” will go back a menu or exit the Administration Menu.

*Note: Default Admin Passcode is 666666.*

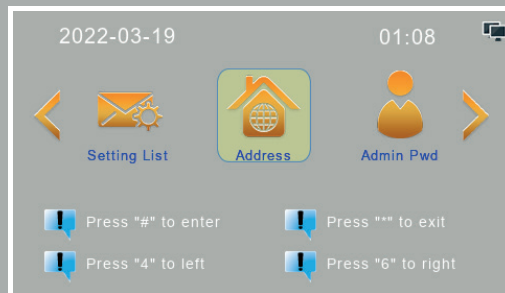

### 1. Setting the Address:

When **Address** is selected press # to enter. If address is not selected, use the 4 and 6 keys to navigate the menu.

Once in the “Address” menu, press “#” to edit the address of the Outdoor Station.

1. When editing the address the field will be highlighted, use “\*” to delete a number, once all 4 digits are entered press #.
  1. If it is the first Outdoor Station set to address to “0101”.
  2. If there are more than 1 Outdoor Station(s) the address can be any value between 0102 ~ 0104.
  3. If there is more than one building to be part of the same system, the first 2 digits (the building) can be any value between 01 ~ 04.

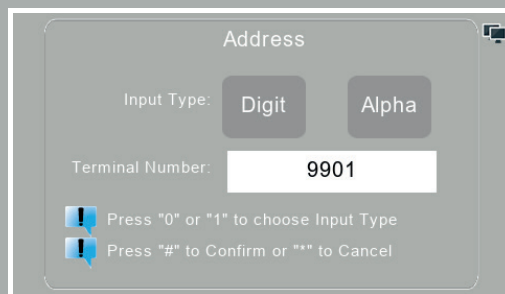

### 2. Setting the Administrator Password

When **Admin Pwd** is selected press # to enter. If **Admin Pwd** is not selected, use the 4 and 6 keys to navigate the menu.

Once in the “Admin Pwd” menu, press “#” to enter in the current password (**6 digits**), and the new password (**6 digits**) twice, and finally press “#” to confirm

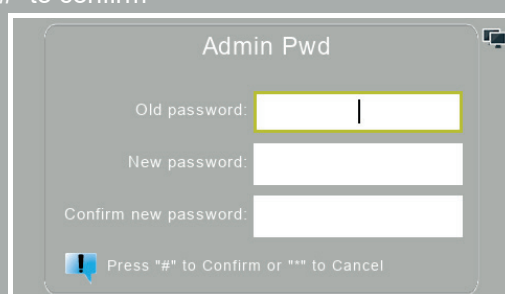

### 3. Setting Public Password

When **Unlock Pwd** is selected press **#** to enter. If **Unlock Pwd** is not selected, use the **4** and **6** keys to navigate the menu.

You will then need to enter the Administration Passcode, and then the new public unlock passcode twice. And then press **#** to confirm and exit the menu.

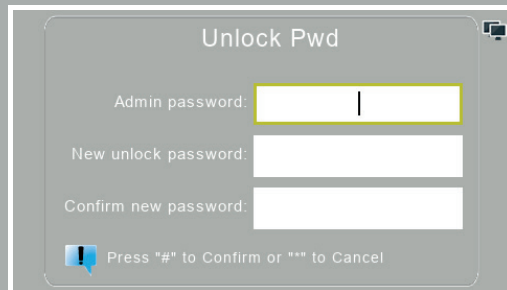

### 4. Password Authority

When **Authority** is selected press **#** to enter. If **Authority** is not selected, use the **4** and **6** keys to navigate the menu.

By default, the unlock methods are disabled.

Press "0" to select disable, press "1" to enable the Public Password, and press "2" to enable the User Password. And then press **#** to confirm and exit the menu.

*Note: User Passwords must be set on indoor monitor(s). See A1IPMW/B Full Manuals for further information*

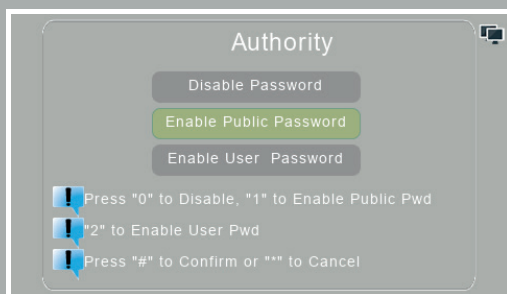

### 5. Volume Setting

When **Volume** is selected press **#** to enter. If **Volume** is not selected, use the **4** and **6** keys to navigate the menu.

You will see Ad Vol which is the global volume & Ring Vol which is the ringing volume.

Press "0" to set the Ad Volume, and press "1" to set the Ring Volume. Once adjusting volumes, press "4" and "6" to adjust volumes up and down. And then press **#** to confirm and exit the menu.

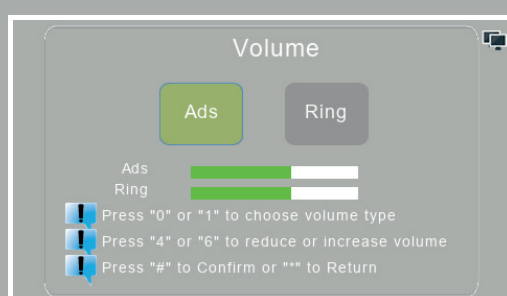

## 6. Unlock Type

When **Unlock** is selected press # to enter. If **Unlock** is not selected, use the 4 and 6 keys to navigate the menu.

By default, the unlock method is "NO" (Normally Open), and a 10 second delay.

Press "0" to choose "NC" (Normally Closed), press "1" to select Power On Lock, then choose your unlock time (Unlock Delay) you can select a time between 1 ~ 150.

And then press # to confirm and exit the menu.

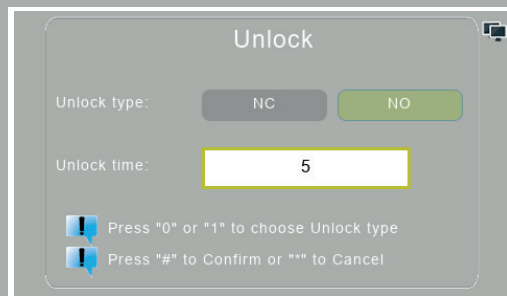

## 7. Sensor Setting

When **Sensor Set** is selected press # to enter. If **Sensor Set** is not selected, use the 4 and 6 keys to navigate the menu.

By default, the unlock method is disabled.

Press "0" to select Disable, and press "1" to Enable, and then "\*" to delete the Open Sensor Delay time. And then press # to confirm and exit the menu.

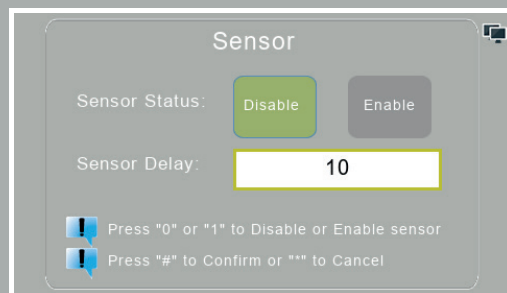

## 8. Language Setting

When Language is selected press # to enter. If Language is not selected, use the 4 and 6 keys to navigate the menu. By default the language is English.

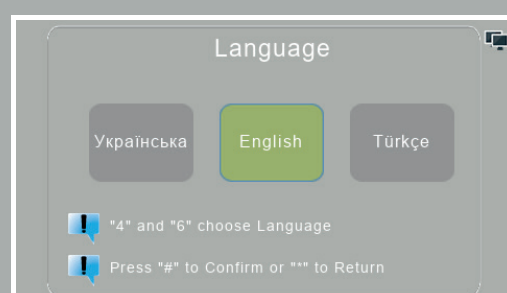



## 9. Date Setting

When Date Set is selected press # to enter. If Date Set is not selected, use the 4 and 6 keys to navigate the menu.

If the Date setting is incorrectly set it will indicate setting failed.

The format should be YYYY-MM-DD HH:MM.

Press "\*" to delete incorrect inputs, press # to confirm and save the inputs.

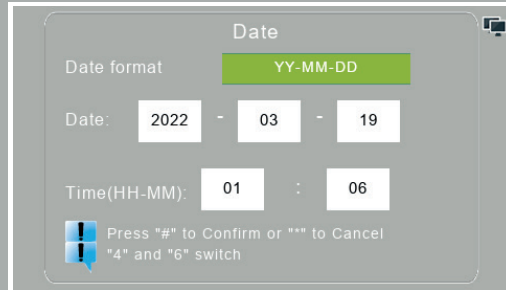

The screenshot shows a 'Date' configuration screen. At the top, 'Date format' is set to 'YY-MM-DD'. Below, the 'Date' is set to '2022 - 03 - 19' and the 'Time(HH-MM)' is set to '01 : 06'. A blue exclamation mark icon is next to the instructions: 'Press "#" to Confirm or "\*" to Cancel "4" and "6" switch'.

## 10. System Information

When Language is selected press # to enter. If Language is not selected, use the 4 and 6 keys to navigate the menu.

The System Information page will show Door No., Local IP Address, Subnet Mask, Gateway Address, Software Version, Producer and NetCfg.



The screenshot shows a 'System' information page with the following details:

Terminal Number	2999999999901
IP Address	192.168.255.3
Gateway	192.168.255.1
Subnet Mask	255.255.255.0
Software Version	2.02.0010
NetCfg	975

## 11. Card Management

When Card Manage is selected press # to enter. If Card Manage is not selected, use the 4 and 6 keys to navigate the menu.

### A. To add user cards/fobs

Press 0 to choose the Add Cards function

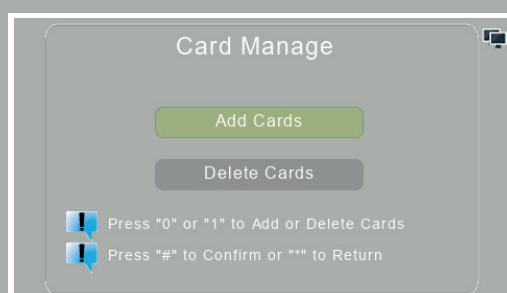

The screenshot shows a 'Card Manage' screen with two buttons: 'Add Cards' (green) and 'Delete Cards' (grey). Below the buttons, there are two instructions with blue exclamation mark icons: 'Press "0" or "1" to Add or Delete Cards' and 'Press "#" to Confirm or "\*" to Return'.

- I. To add an IC card, you will need to assign it to a room number. On the Add Cards screen you will need to enter the room number, and press #. For example for room 159, enter 0159.

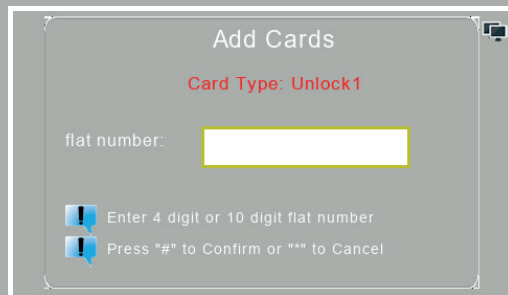

- II. After the correct room number has been inputted, press # to confirm and then once on the below screen, present your card/fob to the card reader, and finally press # to complete adding the card/fob.



## B. To delete users cards/fobs

Press 1, to choose the Delete Cards functions, followed by #.

To delete a card you will need to select either by Card Number, by Room Number or to Delete all local cards, which is 0 , 1 or 2 respectively.

After pressing either 0, 1 or 2, press # to continue the deleting process.

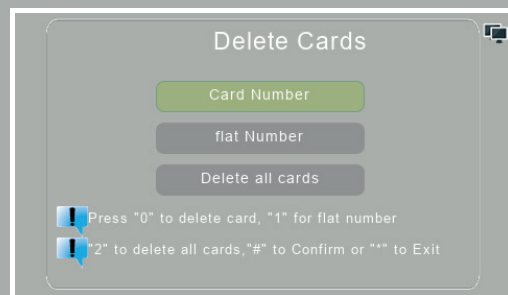

- I. If the delete by Card Number was entered, then enter in the card/fob's ID number and press #. It will then indicate it has been successfully deleted, or the card number does not exist.
- II. If the delete by Room Number was entered, then enter the room number followed by #. For example for room 112, enter 0112. It will then indicate it has been successfully deleted, or the room does not have any cards/fobs.

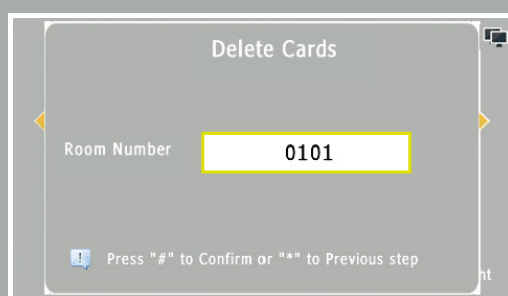

III. Finally, if Delete all local cards, was entered, then press # to confirm to delete all local cards.



## 12. Restore default settings

When Restore is selected press # to enter. If Restore is not selected, use the 4 & 6 keys to navigate the menu. Once on the restore page, if you want to the restore all settings back to factory default press #, the Outdoor Station will then restart.



## 13. Trades Hours

When Restore is selected press # to enter. If Restore is not selected, use the 4 & 6 keys to navigate the menu. Once on the Trade Facility menu, pressing 4 or 6 will enable or disable the function. Pressing # will start the editing sequence to set to time that the trade facility should be active for each day. Using "\*" to delete numbers, # to continue to the next field, and the number pad to set the time. Times for each segment need completing before you can save.

To use the Trades Facility, if you press & hold # when on the A1IPDSM1's standby screen within the configured Trade Hours, will trigger the lock output. This will use the time function as defined in this menu, and as such a 3rd party timer is not needed.



## 6. Installation of Outdoor Units

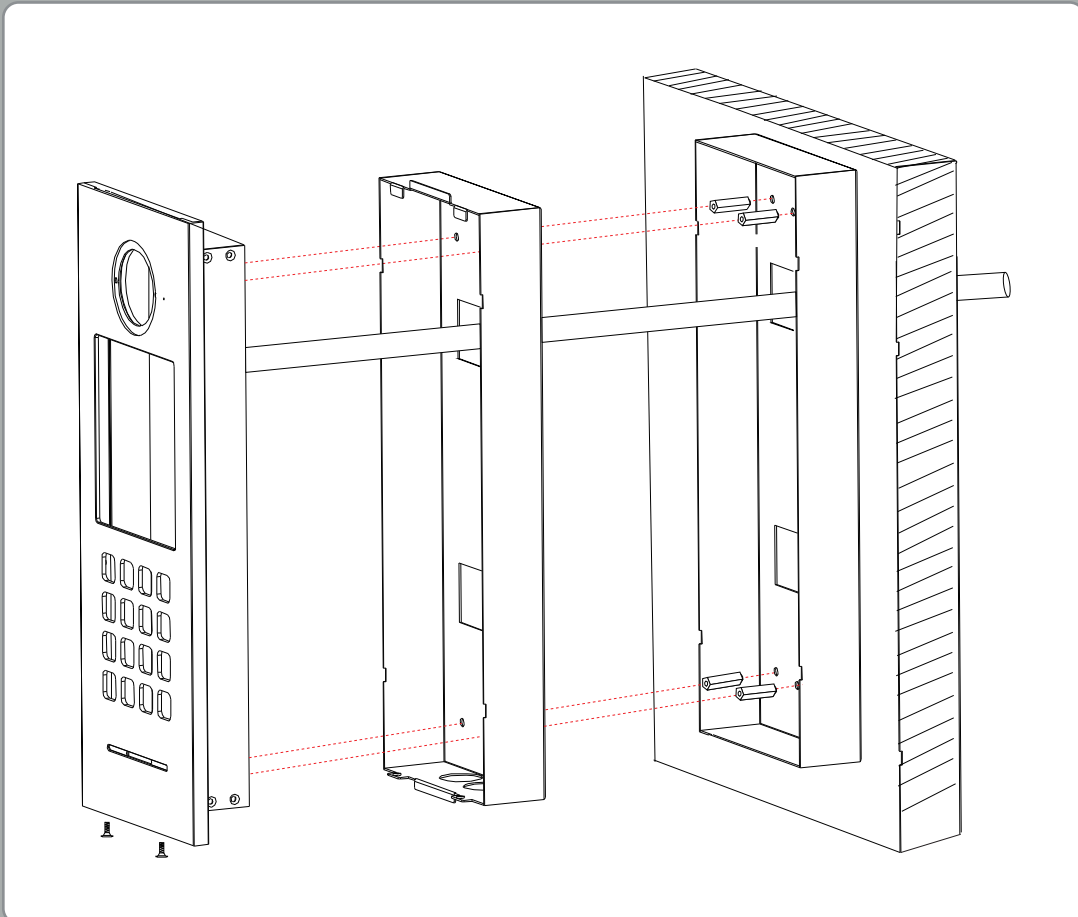
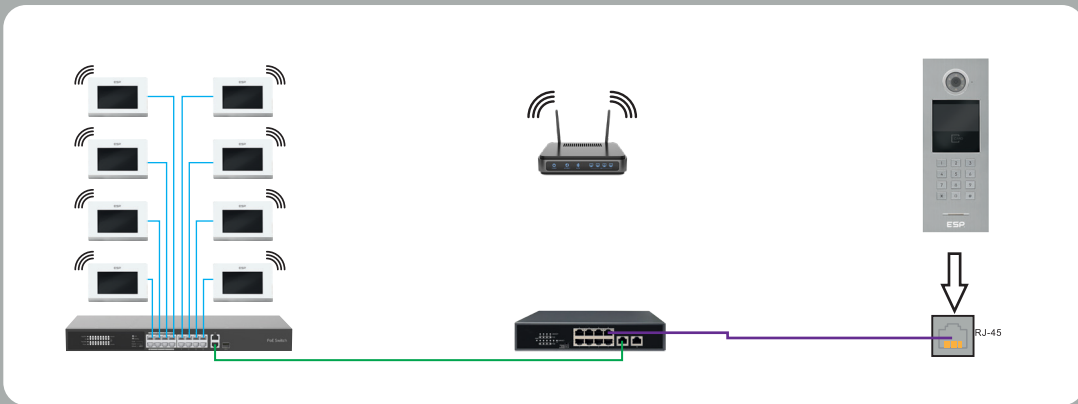
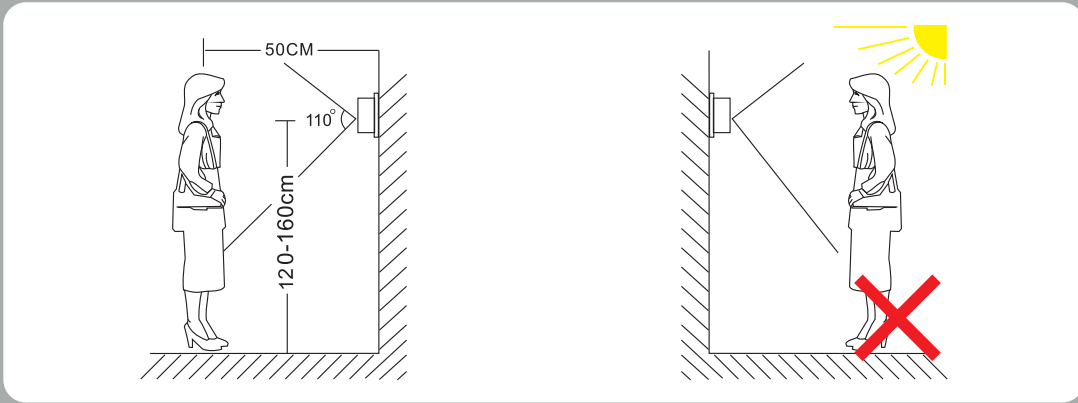

## Contact Details



Elite Security Products UK, Unit 7 Target Park, Shawbank Road, Lakeside, Redditch, Worcestershire, B98 8YN  
Tel: +44(0) 1527 51 51 50 Fax: +44(0) 1527 15 01 43 Email: [info@espuk.com](mailto:info@espuk.com)  
Registered in England, Company Registration Number: 02769392, VAT Registration: GB614686525

For more product information please visit [www.espuk.com](http://www.espuk.com)  
E&OE - Errors and Omissions Excepted. K23

